

# INDUSTRIAL MAINTENANCE, HVAC AND TELECOMMUNICATION TOOLS

Version 3/2018



CALL US FOR YOUR RENTAL NEEDS AT 0800 171 414  
[WWW.RAMIRENT.FI](http://WWW.RAMIRENT.FI)

# CONTENTS

Pages

## Pages

### **LIFTING AND HANDLING EQUIPMENT ..... 4-11**

Material lifts, Repair shop lifts, Chain blocks, Lever chain hoists, Hand chain blocks/ Hand chain hoists, Wire rope blocks, Electric and pneumatic chain blocks, Winches, Mast winches/ Rope winches, Geared trolleys and Beam Clamps, Pulleys, Lifting clamps, Mechanical jacks, Track jacks, Mechanical lift jacks, Ratchet turnbuckles, Hydraulic lift cylinders, jacks, Hand pumps and units, Hydraulic cylinders, Hydraulic hollow-piston cylinders, Hydraulic spreaders.

### **HANDLING AND HAULING EQUIPMENT ..... 12-15**

Hydraulic toe jacks, Transport trolleys, Multi-roller skates, Furniture movers, Stair climbers, Platform carts, Combination carts, Other carts, Tool chests, Bicycles.

### **CABLE TOOLS..... 16-24**

Crimping tools, Cable cutters, Duct rod, Probes and locators, Cable avoidance tools, Metal detectors, Cable pull/ cable laying equipment, Cable stockings and wire grips/Cable clamps, Cable pulleys/rollers, Cable reel handing, Cable reel rollers/Roller platforms, Reel stands for hand trucks, Cable reel stands, Cable reel trailers, Arc protection strippers, Cadweld moulds.

### **PIPEWORK TOOLS.....25-37**

Pipe size metric conversion table, Pipe supports and vises, Machine-powered pipe rollers, Pipefitting press tools/pipe clamps/pressfitting tools, Portable collaring machines, Hot tapping machines, Electric pipe freezers, Hole cutting tool for pipes, Threading machines, Grooving tools, Mechanical pipe benders, Electric pipe benders, Large machine pipe benders, Hydraulic mandrel pipe benders, Beveling machines, Tube lathes, Pipe cutting, Pipe saws, Pipe reciprocating saws, Pipe cutting machines, Pipe centering equipment, Pressure test pumps, Drain cleaning equipment, Pulse flushing compressor, Pipe butt welding, Electrofusion welding units, Steelflex pipe trailers.

### **TORQUE TOOLS..... 38-42**

Hydraulic torque wrenches/Hydraulic ratchets powered by a separate pump, Electric multiple application pumps, Electric and battery-operated torque wrenches, Impact wrenches, Torque converters/Torque multipliers, Torque wrenches, Socket sets, impact sockets and adapters, Striking face box spanners, Striking face box end wrenches, Combination wrenches, Adjustable wrenches.

### **WELDING EQUIPMENT ..... 43-49**

TIG welding machines, Water coolers for TIG machines, MIG welding machines, Manual Metal Arc (MMA) welding machines, Storage and drying of welding electrodes, Smoke extractors, Gas welding equipment, Gas cylinder trucks, Plasma cutting, Hot-air tool, Personal gas detection instruments, Pneumatic chipping hammers and needle scalers, Weld purge monitors.

**FIBRE OPTICS TOOLS ..... 50-56**

Fusion splicers, OTDR instruments/Fibre inspection probes, Ethernet test equipment, Fibre inspection probes, Optical power meters, Optical loss meters, Extension trailers/Splicing trailers, Copper network instruments, XDSL testers, TDR equipment/Cable fault locators/Wire fault locators, Field strength meters, RF testers, Other television network tools, Electrician instruments.

**OTHER TOOLS ..... 57-64**

Workbenches, Dry-cut saws/Metal saws, Band saws for metal, Angle grinders, Die grinders, Rivet nut tools, Blind rivet tools, Threaded rod cutters, Beveller, Punch drivers, Hydraulic pullers, PMR telephones, Fire extinguishers, Hot work carts, Ladders and work platforms, Ixolift Mobile Elevating Work Platforms, Long reach scalers, Pencil drill drivers, Metal core drilling units 220-240 V.

**OTHER METERS AND INSTRUMENTS ..... 65-67**

Thermometers, Sound level/Light meters, Dynamometers, Rope tension meters, Personal radiation monitors, Pipe inspection cameras/Inspection cameras.

**TOOLKITS ..... 68-71**

Installer toolkit, Mechanic toolkit, HVAC installer toolkit, Welder toolkit.

# LIFTS AND LOAD HANDLING EQUIPMENT



## MATERIAL LIFTS

- Well-suited to the installation and maintenance of ventilation ducts and machinery
- The SLA-20 is fitted with side stabilisers
- Also available as 3.1 m and 4.1 m panel lifts
- Available stackers for handling materials

Product category	Model	Max. lifting	Max. load	Transport height	Transport width	Transport length	Working length	Weight
8824	GENIE LIFT GL-10	3,6 m	159 kg	1,97 m	0,73 m	0,49 m	1,09 m	68 kg
8826	GENIE LIFT SLA-20	6,5 m	363 kg	1,99 m	0,80 m	0,74 m	2,08 m	184 kg

## REPAIR SHOP LIFTS / MOBILE BOOM LIFTS



Product category	Model	Capacity	Lifting height	Jib length	Dimensions (k x p x l)	Weight
230404	WJN 10	1,10 t	2020-2340 mm	955-1375 mm	125 x 1420 x 1110 mm	95 kg
230404	WJN 20	2,0 t	2340-2630 mm	1210-1630 mm	160 x 1750 x 1850 mm	250 kg
230404	ABT2000	2,0-1,5 t	230-2705 mm	1290-1590 mm	205x 690 x 1900 mm	165 kg

## CHAIN BLOCKS, HOISTS AND WINCHES

Manually and machine-operated lifting and pulling blocks with chains or wire rope for production or maintenance applications.

- Chains and wire ropes may not be used as lifting eyes.
- Ramirent also rents lifting slings (**straps and wire rope**).
- When planning a lift, we recommend calculating the equipment to ensure that the load does not exceed 80% of the maximum load capacity rated for the equipment.

Chains (weight / per m)		Chains (weight / per m)	
1 ton	0,75 kg	5 mm	9,5 kg
2 ton	0,86 kg	7 mm	19 kg
3 ton	2,35 kg	9 mm	31 kg
6 ton	2,35 kg x 2 (number of falls: 2)	12 mm	55 kg
9 ton	2,35 kg x 3 (number of falls: 3)	15 mm	86 kg
		18 mm	124 kg
		20 mm	153 kg



### ER CHAIN HOISTS

Product category	Model (or equivalent)	Lifting capacity	Chain length	Hook spacing*	Weight (w/o chain)
8830	KITO LX005	500 kg	6 m	246 mm	2,7 kg
8831	KITO NLB008	800 kg	6 m	280 mm	5,7 kg
8832	KITO LB016	1600 kg	6 m	335 mm	8 kg
8833	KITO LB032	3200 kg	6 m	395 mm	15 kg
8834	KITO LB063	6300 kg	6 m	540 mm	26 kg
8834	KITO LB090	9000 kg	6 m	680 mm	40 kg



### CHAIN BLOCKS/HAND CHAIN HOISTS

Product category	Lifting capacity	Chain length	Hook spacing*	Weight (w/o chains)*	Note!
230311	1000 kg	6-10 m	370 mm	13 kg	
230312	2000 kg	6-10 m	n. 425 mm	n. 20 kg	
230313	3000 kg	6-10 m	465 mm	28 kg	2 hanes
230314	5000 kg	13-15 m	636 mm	40 kg	2 hanes
230315	10 000 kg	8 m	810 mm	125 kg	2 hanes

\*\* depending on the model

### WIRE ROPE BLOCKS



Product category	Name	Pulling and lifting load	For wire ropes	Weight	Model
8842	TIRFOR 508	800 kg	20 m/8,3 mm	6,6* kg	Pulling hoist
8843	TIRFOR 516	1600 kg	20 m/11 mm	13,5* kg	Pulling hoist
8845	TIRFOR 532	3200 kg	20 m/16,2 mm	24* kg	Pulling hoist
230300	LUG-ALL 1000-15	380 kg	4,5 m	3,2 kg	Drum model
280301	LUG-ALL 4000-20	700/1400** kg	6 m	7,1 kg	Drum model
* weight (w/o wire rope) ** 1-2 WIRE ROPES					

### ELECTRIC AND PNEUMATIC CHAIN BLOCKS

This category includes chain and wire rope blocks equipped with a suspension hook.



Product category	Model	Type	Lifting capacity	Lifting	Speed m/min	Weight (w/o chanes/ wire ropes)	Note!
230200	MINIFOR TR30	230 V Wire rope	300 kg	15-40 m	5 m/min	21,5 kg	6,5 mm wire rope
230209	KITO WLL240	230V Chain	240 kg	7-20 m	12,9 m/min	15,5 kg	
230210	KITO EFO105D	380V Chain	1000 kg	15 m	6,5/2,2 m/min	52 kg	Other models also available with a 28 m chain
	LIFKET 1 T	380V Chain	1000 kg	15 m	5/1,25 m/min	38 kg	2 chains
230211	KITO EFO20L	380V Chain	2000 kg	24-30 m	3,3 m/min	59 kg	
	LIFKET 2T	380V Chain	2000 kg	15 m	3/0,75 m/min	38 kg	2 chains
	GIS	380V Chain	4000 kg	10 m	n. 3m/min	119 kg (with chain)	2 chains
230102	ATLAS COPCO LLA1000	Pneumatic chain	1000 kg	10-12 m	6,3 m/min	14,5 kg	2 chains
230103	RED ROOSTER TCR-6000	Pneumatic chain	6000 kg	5 m	1,3 m/min	67 kg	2-ketjua

## WINCHES

Floor-mounted winches, which can also be used for lifting.



Product category	Name	Type	Load*	Wire lenght	Speed m/min	Weight (w/o wire rope)	Note!
230201	YALE RPE 5-6	230 V and 400 V	510 kg	25-140 m	6,5 m/min	n. 33 kg	6 mm wire
230203	MC1200/EN1300	400 V	1200 kg	32-40 m	5 m/min	175 kg	8 mm wire
230206	EN-1200	400 V	1200 kg	40 m	2,6 m/min	130 kg	Remote control approx. 30 m 10 mm wire
230207	EN-2800	400 V	2800 kg	90 m	2,2 m/min	340 kg	Remote control approx. 30 m 14 mm
230204	MC2800	380 V	2800 kg	49-80 m	7 m/min	340 kg	13 mm ire
230205	MC5000	380 V	5000 kg	85-150 m	12 m/min	790 kg	18 mm wire

\*Pulling load on the first wind of the rope. When the drum has three winds of rope or lifting the load, the maximum capacity is approximately 77% of the first wind efficiency.

Using hoist with pulleys.

nr of wires

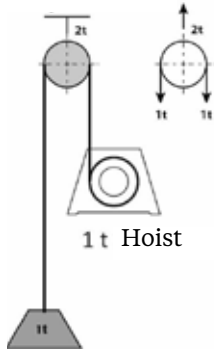

nr of wires

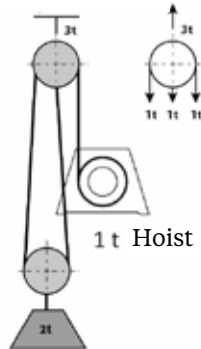

Distance to pulley or load

Tip: (D) should be over 20 times to L

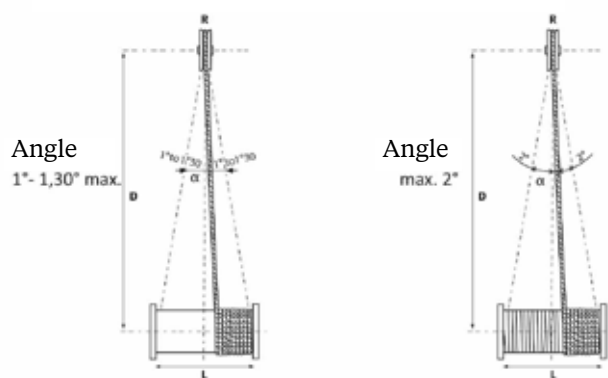

## MAST WINCHES/ROPE WINCHES

- For such applications as equipment transport, line pulling, etc.
- Rope not included.
- Not for personnel lifts!



Product category	Name	Load	Speed	Weight	Note!
270204	TEPA 501	460 kg	9 ore 20 m/min	31 kg	Two-speed
	ELEKTRO 300	300 kg	9-43 m/min	40 kg	Stepless speed control



## GEARED TROLLEYS AND BEAM CLAMPS

For suspending lifting equipment on wide and narrow beams.

Beam clamps I/H (Not for lifting beams)			
Product category	Load capacity	Width of the beam	Weight
250004	1 t	70-255 mm	5 kg
250005	2 t	75-230 mm	5 kg
	2 t	130-350 mm	5 kg
250006	3 t	80-320 mm	10 kg
	3 t	95-360 mm	12 kg
250007	5 t	70-355 mm	12 kg
	5 t	90-310 mm	12 kg
250009	10 t	75-305 mm	16 kg

Geared trolleys for I-beams			
Product category	Load capacity	Width of the beam	Weight
250200	1 t	50-130 mm	10 kg
	1 t	181-300 mm	12 kg
250201	2 t	66-220 mm	20 kg
250202	3 t	74-180 mm	35 kg
250203	3 t	181-300 mm	40 kg
	5 t	82-180 mm	55 kg
	5 t	181-300 mm	60 kg
250204	20 t	125-310 mm	230 kg



## PULLEYS

- Single or double side-opening pulleys for wire rope
- Available with a shackle and hook
- Slide bearings



Product category	Model	Load capacity	Wire rope diameter	Weight	Note!
250100	ALPS 15	0,75-1,5 t	5-8 mm	4 kg	With hook
250101	SVERO 71/ALPS 25	2-2,5 t	6-10 mm	10 kg	With hook or shackle
250102	SVERO 71	3-4 t	7-12 mm	12 kg	With hook or shackle
250104	MCKISSICK 419	8 t	16-19 mm	25 kg	With shackle or double
	MCKISSICK 409	12 t	16-19 mm	26 kg	With shackle or double



## LIFTING CLAMPS

Articulated and fixed lifting points (depending on model).

Plate clamps for horizontal lifts. To be used in pairs			
Product category	Load capacity	Thickness, lift	Weight
250001	1,5 t	0-50 mm	10 kg
	3 t	0-100 mm	19 kg
	4,5 t	0-40 mm	16 kg
	6 t	0-152 mm	28 kg
<b>Bulb-profile clamp</b>			
250008	750 kg	100-220 mm	4 kg
	1500 kg	100-220 mm	4 kg
	3000 kg	100-220 mm	4 kg

Plate clamps for vertical lifts			
Product category	Load capacity	Thickness, lift	Weight
250000	750 kg	0-13 mm	5 kg
	1,5 t	0-20 mm	8 kg
	2 t	0-20 mm	8 kg
	2 t	0-32 mm	8 kg
	4 t	0-25 mm	16 kg
	4,5 t	0-35 mm	16 kg
6 t	0-50 mm	25 kg	



Horizontal plate clamp



Bulb profile clamp



Plate clamp

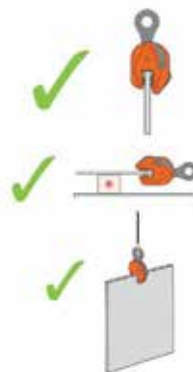
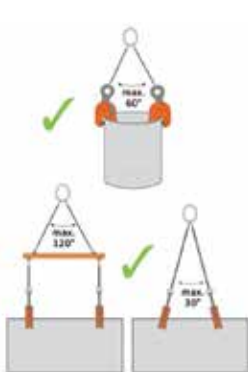
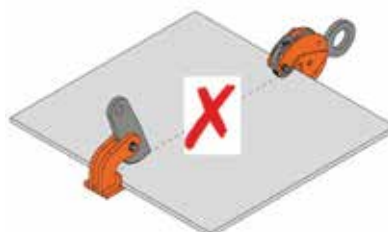

Plate clamps require 10% from max. load in order for them to work property.





### MECHANICAL JACKS

The advantage offered by mechanical jacks is that they do not require oil and can be used in any position.

**Maximum height = height + stroke**

### TRACK JACKS

- Toe included standard
- Steel construction
- Solid
- Estimated rise under 10 mm/cycle

Product category	Model	Capacity	Stroke	Height	Toe height	Weight
230001	HAACON 11,3 R	3 t	300 mm	725 mm	79 mm	20 kg
	HAACON 11,5 R	5 t	300 mm	722 mm	77 mm	27 kg
	TRACTEL TOP BT5	5 t	354 mm	735 mm	80 mm	28 kg
	TAIFUN 11-10	10 t	300 mm	800 mm	80 mm	42 kg
	TAIFUN 11-20	20 t	400 mm	800 mm	100 mm	58 kg



### MECHANICAL LIFTING JACKS

Extremely durable, oil-free jacks for heavy-duty applications

Product category	Model	Capacity	Stroke	Height	Weight
230002	HOLMATRO JJ3513	35 t	130 mm	280 mm	24 kg

### RATCHET TURNBUCKLES

Compact, lightweight and versatile mechanical push/pull tool for installation and maintenance work.



Product category	Order no.	Capacity	Stroke	Length min.	Weight: mechanism + shaft
270302	J10(1A)	10 t	100 mm	340 mm	4,5 + 0,9 kg
270302	J12 (1B)	12 t	200 mm	490 mm	6,0 + 1,2 kg

### HYDRAULIC CYLINDERS, JACKS, PUMPS AND UNITS

This category includes cylinders, spreaders and their 700 bar hydraulic units, which are primarily used for lifting.

#### Hydraulic pumps



- Benefit of using hydraulic pump and cylinder instead of bottle jacks is that cylinders can be used in every position and are more compact in size.
- Choose the pump that contains enough oil for your tool.
- **Hydraulic pumps are shipped with a 1.8 m hose (threaded quick-release coupling)**
- By using the pump, cylinder can be used remotely and the cylinder can be placed in tight, otherwise inaccessible spaces.

Product category	Model	Function	Tank size	Output (min- max) L/min or cm3/stroke	Weight	Note!
230013	POWER TEAM P19 or equivalent	2-peed	0,33 l	5/1,2	3 kg	manual
	POWER TEAM P55 or equivalent	1-peed	0,74 l	2,5	7 kg	anual

## HYDRAULIC CYLINDERS

We offer a selection of low and short cylinders. All our cylinders are spring return and work in all positions.



Product category	Model	Capacity	Stroke	Height	Weight	Oil volume
230009	POWER TEAM RLS100	10 t	11 mm	45 mm	1,5 kg	0,01 l
	POWER TEAM RSS101/BVA HL 1001	10 t	38 mm	89 mm	2,7 kg	0,05 l
230010	POWER TEAM RLS200	20 t	11 mm	51 mm	2,5 kg	0,01 l
	POWER TEAM RSS202/HL 2002	20 t	45 mm	95 mm	4,5 kg	0,12 l
	POWER TEAM RLS300	30 t	13 mm	67 mm	6,4 kg	0,05 l
230011	ENERPAC RSM500	50 t	16 mm	66 mm	7 kg	0,1 l
	POWER TEAM RSS502	50 t	60 mm	127 mm	10,5 kg	0,4 l
	ENERPAC RCS502	50 t	60 mm	122 mm	10 kg	0,4 l
230012	ENERPAC RMS1000	90 t	16 mm	85 mm	14,5 kg	0,2 l
	POWER TEAM RSS1002	90 t	57 mm	140 mm	21,5 kg	0,7 l
	POWER TEAM RLS1000S	90 t	16 mm	86 mm	13,5 kg	0,2 l

## HYDRAULIC HOLLOW PISTON CYLINDERS

Low, spring return hollow piston cylinders for such applications as extraction and tensioning.



Product category	Model	Capacity	Stroke	Height	Hole	Weight	Oil volume
230010	POWER TEAM RH203	17 t	76 mm	153 mm	25,7 mm	9 kg	0,2 l
	ENERPAC RCH202	20 t	50 mm	155 mm	27,3 mm	7 kg	0,14 l
230009	BVA HC1203XT	12,5 t	76 mm	184 mm	19 mm	3,9 kg	0,14 l
230011	POWER TEAM RH603	56 t	76 mm	235 mm	54,1 mm	27,2 kg	0,6 l
230010	POWER TEAM RH302	30 t	63,5 mm	159 mm	32,9 mm	11,5 kg	0,25 l

## HYDRAULIC SPREADERS

Effective hydraulic spreaders for such applications as spreading flanges. Spreaders require a separate pump.



Product category	Model	Capacity	Stroke	Height	Weight
230007	EXTRACTIL 15TLS	15 t	10 mm	5-40 mm	5 kg

# MACHINE TRANSPORT AND LOGISTIC EQUIPMENT

Used to move heavy equipment, machines or units during installation or maintenance work.



## HYDRAULIC TOE JACKS

The toe allows for lifts to be made with very little clearance.

The toe boot offers a floating Slide Shoe feature and lift height can be adjusted, if necessary. It is also possible to lift from the end of the jack.

On Jung toe jacks, the pump and jack are compactly built into the same unit. It is also possible to use a separate 500 bar pump.

Product category	Name	Capacity	Toe height - mm (min-max/ lifting points x spacing)	Toe depth (usable)	Stroke height	Height	Weight
230015	JH6G+	6 t	12-157 (6 x 29)	59 mm	140 mm	245 mm	23 kg
	JH10G+L	10 t	15-138 (4 x 41)	54 mm	113 mm	233 mm	25 kg
	JH10G+	10 t	15-180 (5 x 41)	54 mm	150 mm	275 mm	29 kg



## TRANSPORT TROLLEYS

Jung transport trolleys are equipped with floor-friendly JUWA polyurethane composite casters.

Trolleys with different load capacities may be used together, provided that the equipment has the same structural height (generally 110 mm).



### Single transport trolleys with 360-degree turning castors

Product category	Name	Load capacity	Height	Exterior dimensions (L x W)	Weight
270100	JLB3K-JUWA	3 ton	110 mm	675 x 435 mm	37 kg



### Front end transport trolleys with geared saddle and bar for pulling

Product category	Name	Load capacity	Height	Exterior dimensions (L x W)	Weight
270100	JL3K	3 ton	110 mm	22 x 280 mm	12 kg
270101	JL7K	7 ton	110 mm	445 x 590 mm	36 kg
	JL14K	14 ton	110 mm	580 x 1000 mm	64 kg

**Back end transport trolleys. Equipped with a connecting bar and two straight-running trolleys**



Product category	Name	Load capacity	Height	Exterior dimensions (L x W)	Adjustment range	Weight
270100	JF3K	3 ton (2 x 1,5 ton)	110 mm	190 x 125 mm	125-880 mm	11 kg
270101	JF7K	7 ton (2 x 3,5 ton)	110 mm	325 x 200 mm	400-1030 mm	27 kg
	JF14K	14 ton (2 x 7 ton)	110 mm	325 x 390 mm	400-1030 mm	35 kg

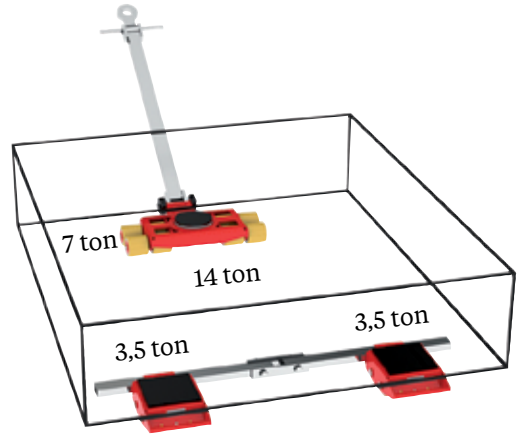

**METAL TRANSPORT TROLLEYS**

Dorvic transport trolleys with metal casters. Comes in a set of 4. Not recommended for sensitive flooring.

Product category	Name	Load capacity	Exterior dimensions* (H x L x W)	Weight
270102	DORVIC A	20 ton	58 x 210 x 102 mm	20 kg
270102	DORVIC B	40 ton	95 x 271 x 125 mm	50 kg
270102	DORVIC C	75 ton	130 x 370 x 175 mm	115 kg

\* The turntable adds approx. 50 mm to the overall height



### FURNITURE MOVERS

- Furniture movers meant for moving of safes, tool chests and other heavy objects.
- Polyurethane casters
- Two items = complete set



<b>Product category</b>	270600
<b>Capacity</b>	1,8 t
<b>Type</b>	FM 180 A
<b>Lifting height</b>	250 mm
<b>Wheels (no. x mm)</b>	4 x 200 mm
<b>Weight</b>	80 kg

### STAIR CLIMBERS

For heavy, difficult moves.



Product category	Name	Capacity	Weight	Note!
270011	SAL 170 FOLD-L	170 kg	20 kg	Speed: 29 steps/min.
	HD330 FOLD DOLLY	330 kg	45 kg	Two-speed 6 or 10 steps/min.

### PLATFORM CARTS

width ø 420 mm tyres



<b>Product category</b>	270003
<b>Load capacity</b>	500 kg
<b>Dimensions</b>	150x80 cm
<b>Weight</b>	approx. 50 kg
<b>Pallet height above ground</b>	420 mm

### COMBINATION CARTS

1500 kg  
4 wheel  
with 260 mm PU tyres



<b>Product category</b>	270009
<b>Load capacity</b>	1500 kg
<b>Dimensions</b>	75x150 cm
<b>Weight</b>	50-80 kg
<b>Pallet height above ground</b>	360 mm

## OTHER CARTS

- Hand trucks
- Specialised trucks for pipes and other long good transport

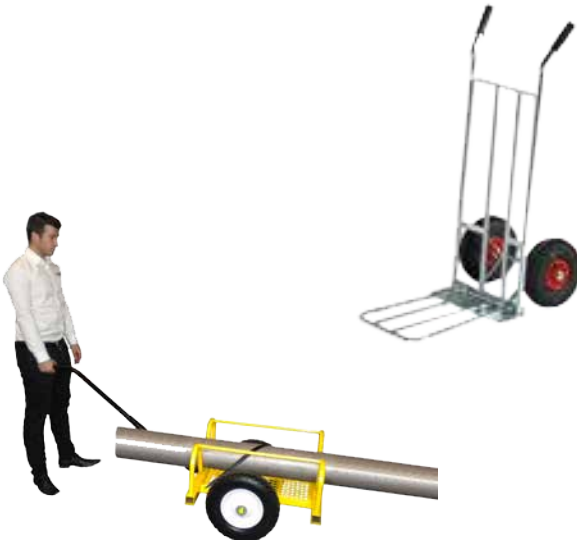

HAND TRUCKS V24, WITH SOLID TYRES	
<b>Dimensions (W x H)</b>	590 x 1250 mm
<b>Nose dimensions (s x l)</b>	230 x 380 / 650 x 320
<b>Weight</b>	18 kg
<b>Tires</b>	260 mm
<b>Product category</b>	270010

PIPE DOLLIES/LONG OBJECT CARTS	
<b>Dimensions (L x W x H)</b>	600 x 650 x 760 mm (Length w/ handle: 1600 mm)
<b>Load</b>	200 kg
<b>Weight</b>	15 kg
<b>Tires</b>	260 mm
<b>Product category</b>	270004

## STARKE ARVID TOOL CHEST

Tool chests with padlock base, castors for moving and inlets for cables



<b>Product category</b>	890102
<b>Max. load</b>	500 kg
<b>Width</b>	650 mm
<b>Length</b>	1200 mm
<b>Height (w/ wheels)</b>	1000 mm
<b>Weight</b>	115 kg
<b>Volume</b>	450 l

## CYCles for industrial use



Product catalogy	Name	Weight	Note!
270007	HELKAMA PRO 1	19 kg	1-gear. Capacity 30 kg
	HELKAMA CARGO TRIKE	32 kg	3-gears. Plastic box included 750 x 550 x 400 mm



# CABLE TOOLS

## CRIMPING TOOLS

When crimping cable terminals, it must be ensured that the terminals are crimped with the tools specified by the manufacturer. Ramirent crimping tools are primarily manufactured by Elpress. For example, when crimping Ouneva connectors, the user must consult Ouneva regarding which dies should be used for which terminals.

Below is a list of the tools/dies included with Elpress crimping tools.



PV1300



PVL 611

		Must be ordered separately			
<b>Tuoteryhmä</b>	660101	066011000000			660101
<b>Nimike</b>	PV1300	Aluminium die set for the PVL1300 crimping tool+ V1320 matrix holder			PV611
mm <sup>2</sup>	Included Cu (RKF/SKF) crimp heads* +V1318 Outer die holder +V1316 Inner die holder	Al stranded mm <sup>2</sup> (matrix + punch)	Al solid mm <sup>2</sup> (matrix + punch)	Preforming (matrix + punch)	Included Cu (RKF/SKF) dies
10	-	-	-	-	TB8-17
16	B9	P13M+D	P13M+D	-	TB9-13
25	B11	P13M+D	P13M+D	-	TB11-14,5
35	B13	P20M+D	P13M+D	-	TB9-13
50	B14,5	P20M+D	P20M+D	-	TB11-14,5
70	B14 (B16 KRT/KST&KRD/KST	P20M+D	P20M+D	-	TB8-17
95	B20	P25M+D	P20M+D	-	TB7-20
120	B22	P25M+D	P25M+D	-	KB22
150	B25	P25M+D	P25M+D	-	KB25
185	13B27 / (B27+B28 esim. OLA)	13P32M+D	P25M+D	13R18MR+DR	-
240	13B30 / (B30 esim. PK-240)	13P32M+D	13P32M+D	13R20MR+DR	-
300	13B32	13P37M+D	-	-	-
400	13B38	13P37M+D	-	-	-
500-1000	-	-	-	-	-
<b>Branch</b>					
10-6	-	-	-	-	TBC4-C8-9
16-10	-	-	-	-	TBC5-C6
25-16	BC6	-	-	-	TBC5-C6
50-16	BC8-9				TBC4-C8-9
70-50	BC11	-	-	-	-
95-70/ 300-240	-	-	-	-	-

\*For Elpress terminals and connectors. Check the crimping instructions for your chosen terminals and connectors.

All 13Dxx type dies are to be used without die holders.



Pump + hose + V250 crimpingtool



V1470 crimping head

	<b>Erikseen saatavissa</b>				
<b>Product catalog</b>	660102	066010000000			660107
<b>Name</b>	PS710E pump (incl. battery, hose) +V250 crimp head + V2508 Outer die holder + V2506 Inner die holder	For aluminium terminals (240-630 mm <sup>2</sup> ) crimp heads + V2531 matrix holder +V2540 preforming punch holder Incl. punches			V1470 crimp head +V1471 matrix holder incl. punches
mm <sup>2</sup> (Elpress terminals and connectors)	Including Cu dies	Al stranded mm <sup>2</sup>	Al olid mm <sup>2</sup>	Preforming	Al stranded
10	-	-	-	-	-
16	B9	-	-	-	-
25	B11	-	-	-	-
35	B13	-	-	-	-
50	B14,5	-	-	-	-
70	B16/B17	-	-	-	-
95	B20	-	-	-	-
120	B22	-	-	-	-
150	B25	-	-	-	-
185	B27	P32M+D	-	-	-
240	B30	P32M9+D	P32M+D	R20MR+DR	-
300	B2532	P36M+D	P36M+36/40/44D	R21MR+DR	-
400	B2538	P40M+D	P36M+36/40/44D	R26MR+DR	-
500	B2542	P44M+36/40/44D/P2552M+D	P36M+36/40/44D	R28MR+DR	-
630	-	P2552M+D	-	-	-
800	-	-	-	-	W60M
1000	-	-	-	-	W60M
Branch	-	-	-	-	-
10-6	-	-	-	-	-
16-10	BC5	-	-	-	-
25-16	BC6	-	-	-	-
50-16	BC8-9	-	-	-	-
70-50	BC11	-	-	-	-
95-70	BC13	-	-	-	-
120-95	BC15	-	-	-	-
150-120	-	-	-	-	-
185-150	-	-	-	-	-
300-240	-	-	-	-	-

### CABLE CUTTING TOOLS

We offer a selection of hydraulic cable cutting tools, which are designed to cut copper and aluminium cables. We also carry mechanical cutters, which can be used to cut stronger materials.



B-TC051



B-TC950



B-TC650SC

Product category	Example*	Model	Cable package max.	Weight	Note!
660120	CEMBRE B-TC051	Pistol model with a closed cutting head	ø 50 mm	4 kg	Cu-Al, Rotating head
	CEMBRE B-TC950	Pistol model with a closed cutting head	ø 95 mm	8 kg	Cu-Al, Rotating head
660121	ELPRESS KL-1485	Cutting head powered by a separate pump	ø Cu: 50 mm/Al 85 mm	10 kg	Cu-Al, Requires e.g. PS710E pump
660127	CEMBRE B-TC-650SC	Pistol model with an open scissor head	ø 65 mm	8 kg	Cu-Al, Rotating head
660123	PORTER 6890FH	Mechanical scissors	ø 30 mm	5 kg	Hard cable: ACSR, ACAR, ZEBRA and self-supporting telephone cables

\* This product category includes several models, whose features may vary from type to type.



PORTER 6890FH

## DUCT RODS



Duct rods can be used for such applications as installing ducts, drainpipe cleaning with brush fittings and inspecting ductwork/pipework with mountable probes.

In addition to small hand-held reels, Ramirent also carries trailer-mounted solutions for jobs requiring long rods. This equipment uses a combustion engine to push and pull the rod, but we do not recommend using them to pull electrical cables through conduit as the creeper/pushrod may break.

Product category	Model	Length	Thickness	Material	Note!
270410	Reel-mounted	40-120 m	8-11 mm	Fibreglass/Nylon	M12 thread on the end for
800080	Trailer-mounted PST1000 (pull/push 3,5 kN)	150-400 m	12 mm	Fibreglass	Equipped with a combustion



## PROBE + LOCATOR

The probe is intended for such applications as pipe inspection using the locator. Not included with the inspection cable reel.



Product category	Name	Weight	Further information
1710	CL43 + PL-18-33 (Locator + pipe probe)	1,5 kg	Probe PL-18-33: Ø 18 mm; 33KHZ; M12 Finder CL43: 10KHZ; 33 KHZ

## CABLE AVOIDANCE TOOLS

Cable avoidance tools are used to locate the position of underground cables. The equipment comes with a receiver and transmitter (alligator clips and clamp included).

The receiver can be used to locate a "live cable" (50/60Hz) without the transmitter. The transmitter can be used to feed a frequency to a dead cable (with the clamp, alligator clips or inductively), so that the receiver can detect the cable.

Also available is the EMS (Electronic Marker System), which can be used to locate and read EMS antennas, which have been placed underground to indicate the location of, for example, a man-hole cover or other hard-to-find object.



Product category	Name	Depth specified by the manufacturer	Weight	Further information
841312	CAT4+ ja GENNY4+	Power (50/60Hz): 2-3 m Radio (15kHz-30kHz): 1-2 m Genny4 (33kHz; 133kHz): 2-4 m	4 kg	Depth measurement ± 10% Genny Power: 1W
	Dynatel 2210/2210E	Power (60Hz): 1,5-3 m Transmitter (577Hz; 33kHz): 2-4 m	5 kg	Depth measurement: ± 15% Transmitter power: 1W

## CABLE AVOIDANCE TOOLS WITH EMS



Product category	Name	Depth specified by the manufacturer	Weight	Further information
841318	Dynatel 2550E-iD	Power (50/60Hz): 1,5-4,5 m Radio (31,5kHz): 1,5-4,5 m Transmitter (577kHz; 1kHz; 8kHz; 33kHz; 82kHz; 133kHz): 1,5-4,5 m	4 kg	Depth measurement ± 2-10% Transmitter power: 1W (12W)*

\* Typically 1W, but with an external power source 12W is possible (except for high frequencies such as 33kHz, which are always 1W).

## METAL DETECTORS



Product category	Name	Depth specified by the manufacturer	Weight	Further information
1712	C.SCOPE CS440XD	Paljastaa suuret metallit yli 1m syvyydestä	1,5 kg	17 kHz

Locates larger metal objects from approx. 1 m deep

## CABLE PULLERS



Tepa 515



Tepa 500

Ramirent has the necessary tools and equipment for pulling underground cables. When considering cable pulling equipment, attention should be given to the cable's tensile strength, the distance being pulled, terrain, bends, etc. If the distance is long or there are several bends, adding a cable dog to help push the cable is recommended. When using more than one machine at the same time, it is important to run them on the same current for ensuring synchronisation.

	Product category	Model	Pull/push load	Speed	Weight	Note!
POWER 380V	270200	RK-700S	Pull + push: 600 kg	15 m/min	250 kg	Cable approx. 150 m
		NKH-B200	Pull + push: 800 kg	11 m/min	200 kg	Cable approx. 150 m
COMBUSTION ENGINE	270201	NKH-B200GS	Pull + push: 800 kg	11 m/min	220 kg	Cable approx. 150 m
		RK-700P	Pull + push: 600 kg	15 m/min	250 kg	Cable approx. 150 m
DRILL OPERATED	270202	TEPA500	Pull: 500 kg	3-10 m/min	15 kg	Incl. drill, frame, 50 m cable, rope drum
	270203	TEPA515	Push: 300 kg	3-10 m/min	2 kg	Incl. drill, frame, pushing device and pressing rollers

## CABLE STOCKINGS AND WIRE GRIPS/CABLE CLAMPS



These are used when pulling cables with pulling tools, thus preventing damage to the cable.

**NOT FOR LIFTING.**

Product category		Size
270406	Wire grips/cable clamps	6-35 mm <sup>2</sup> (Ø 3-8 mm), 12-26 mm <sup>2</sup> (Ø 4-12 mm), 16-70 mm <sup>2</sup> (Ø 4-12 mm), 50-150 mm <sup>2</sup> (Ø 6-18 mm), 1-10 mm <sup>2</sup> , 1-5 mm <sup>2</sup> Gufe 16-70 mm <sup>2</sup> (Ø 5-12 mm)
270407	Cable stockings, length 60 cm	10-20 mm, 20-30 mm, 30-40 mm, 40-50 mm, 50-65 mm, 65-80 mm, 80-95 mm/60cm, 90-110 mm, 110-130 mm
270408	Cable stockings, side opening	20-30 mm, 40-50 mm, 65-80 mm, 95-110 mm

## CABLE PULLEYS

suitable number of pulleys facilitates cable movement when pulling cables. It also prevents damage to the cable caused by rubbing.



Product category	Model	Type	Mount	Sheave groove	Weight
270400	1 sheave	AMKA ST26.33	RKKP-& RKKUH	76 mm	2,2 kg
270401	2 sheaves	SAMKA /PLR30-2/130	Link	110 mm	5 kg
270402	Floor	ST157	With mounting	180 mm	4 kg
270404	Floor/angles*	ST158		180 mm	10 kg

\* Can be used together to form an angle



## CABLE REEL HANDLING

Ramirent carries products designed to handle large and small cable reels. Small reel tables for smaller applications and large hydraulic reel stands for reels up to K34. We also offer small cable reel trailers, which can be towed to a job site.

### CABLE REEL TABLE

Reel type	K4	K5	K6	K7	K8	K9	K10	K11	K12	K14	K16	K18	K20	K22	K24	K26	K28	K30	K32
Flange ø	400	500	600	700	800	900	1000	1100	1200	1400	1600	1800	2000	2200	2400	2600	2800	3000	3200
Drum ø	175	200	250	325	375	425	500	575	675	800	950	1100	1300	1400	1400	1500	1500	1500	2400
Interior width	300	400	400	500	500	550	600	650	850	850	850	850	1000	1000	1000	1200	1350	1500	1600
Centre hole ø	75	75	75	75	75	75	75/101	104/101	104/101	104/101	104/101	132/140	132/140	132/140	132/140	132	132	132	132
Exterior width	330	130	168	580	580	630	712	762	982	982	1018	1075	1188	1188	1200	1448	1650	1800	1970
Unladen weight (kg)	2	8	12	20	25	34	45	55	90	115									



## CABLE ROLLERS/ROLLER PLATFORMS

Product category		Dimensions	Load capacity	Reel	Weight
270502	GKT 650	710 x 710 x 60 mm	800 kg	K4-K9	18 kg
	RB 4.1	530 x 370 x 103 mm	80 kg	K3-K4	3,5 kg
	RB 6.1	680 x 470 x 103 mm	250 kg	K5-K8	5 kg





## REEL STANDS FOR HAND TRUCKS

KAP60 is intended for moving small reels and, when in its horizontal position, it can be used as a reel stand for small cables.

Product category	Name	Load capacity	Reel max.	Weight
270502	KAP60	150 kg	K6 (600 mm)	25 kg

## CABLE REEL STANDS



Hydraulic reel stands for handling larger cable reels. The base height can be adjusted and, in most cases, our cable reel stands are fitted with bearings. Each reel stand is its own product.

**A complete package consists of two cable reels and an axle.**

Product category	Name*	Load capacity (pair)**	Reel max.**	Weight**
270409	Reel stand KK2000	2 ton	K14 (1,4 m)	8 kg
270500	LKP6000	3-5 ton	K20-K24 (2-2,4 m)	55 kg
270501	HRL7000	5-14 ton	K28-K37 (2,8-3,7 m)	180 kg

\* several models in the category

\*\* depending on the model



### AXSELS

- basic rod 270500 for category: 923639000000
- 7 tonne w/ bearings for stand HRL7000: 923637000000
- 14 tonne w/ bearings for stand HRL14000: 923638000000



## CABLE REEL TRAILERS

Product category	Model	Max. reel weight	Max. reel type	Reel mount width	Axle ø	Trailer width	Note!
800001	JOKO600	750 kg	K18 (1800 mm)	1025 mm	60 mm	1760 mm	
800003	JOKO1000	750 kg	K22	1400 mm	60 mm	2200 mm	
800006	JOKO1100	1200 kg	K22	1400 mm	60 mm	2200 mm	
800009	JKS1500	1000 kg	K22	1400 mm	60 mm	2200 mm	Motor
800015	JKS2500	2100 kg	K24	1400 mm	60 mm	2200 mm	Bogie-mounted, motor



## ARC PROTECTION STRIPPER



Name	For arc protection
<b>XLV-3245</b>	<45 mm
<b>XLV-3345</b>	<45 mm
<b>XLV-3285</b>	35-85 mm

## CADWELD MOULDS

Ramirent offers the Cadweld Multi Kit-CDM-V01 welding kit without the related parts and materials (e.g. gaskets, powders, etc.). The kit is intended for the welding of ground rods and rope (extension, branch, cross, rebar and ground rod welds).



- Copper or steel rope connection to the ground rod
- Copper and steel ropes and rebar max. diameter approx. 10mm (~50mm<sup>2</sup>)
- Copper and steel strips max. 30x3.5mm

Includes:

- 1 Mould for H welds (CDM-V01-H)
- 1 Mould for welds on 1/2" (12.5 mm) rods (CDM-V01-12)
- 1 Mould for welds on 5/8" (14.2 mm) rods (CDM-V01-58)
- 1 Mould for welds on 3/4" (17.2mm) rods (CDM-V01-34)
- 1 Handle clamp (FM-CDM-V0) + Clamp (SKK1)
- 1 Toolset (TS-CST): steel brush, cleaning brush
- 1 Slag removal spade (B136B)
- 1 Cadweld Plus control unit (PLUSCU) + pistol-style flint igniter
- 1 User instructions
- 1 Metal carrying case

# PIPE TOOLS

## PIPE SIZE METRIC CONVERSION TABLE

Always check the wall thickness if you need to know the inner diameter

NOMINAL SIZE (DN)	OUTER DIAMETER	THREAD SIZE (INCHES)
6	10,3	1/8"
8	13,7	1/4"
10	17,1	3/8"
15	21,34	1/2"
20	26,67	3/4"
25	33,4	1"
32	42,16	1"1/4
40	48,26	1"1/2
50	60,3	2"
65	76,1	2"1/2
80	88,9	3"
100	114,3	4"
125	139,7	5"
150	168,3	6"
200	219,1	8"
250	273	10"
300	323,9	12"
350	355,6	14"



**PIPE SUPPORTS AND VISES**



Ridgid 560



Ridgid 460-6

Product category	Name	Weight	For pipes	Further information
310401	Ridgid 560	12 kg	3-125 mm (1/8-5")	With chain vise
	Ridgid 460-6	20 kg	3-150 mm (1/8-5")	With chain vise
330304	AMA-pukki A	33 kg	16-600 mm 1500 kg	Pipe fastening chain + rollers
	AMA-pukki B	14 kg	16-600 mm 560 kg	Ball-bearing
	AMA-pukki C	6 kg	15-600 mm 250 kg	Stand only
921406000000	FOLD-A-JACK	13 kg	10-300 mm 450 kg	Rubber wheels
921404000000	Ridgid VJ-99	12 kg	30-300 mm 450 kg	Ball-bearing



AMA-pukki A



AMA-pukki B



AMA-pukki C



Fold-A-Jack

**MACHINE-POWERED PIPE ROLLERS**

Product category	Name	Capacity	For pipes	Speed	Weight
330300	PEMA 5TA PEMA 5TXA	5 tonnes (15 tonne rive capacity)	1250-4500 mm (50% apacity 500-4500)	60-1250 mm/min	Support 590 kg
					Rotator 925 kg
330301	PEMA 1000S	750 kg rotary welding table	100-1000 mm (with pipe)	60-1200 mm/min	580 kg



## MACHINE-POWERED WELDING POSITIONERS



Product category	Name	Capacity	Table plate diameter	Range of motion	Weight
330302	PEMA ahma 1500-400 V	15000N*	700 mm	775-1550 mm 135°	730 kg

\* Depending on the distance from the centre of the workpiece to the table plate or centre of the table plate.



## PRESSFITTING TOOLS

Ramirent carries tools for use in cold pipe pressfitting and making Mapress fittings.

M-tongs = Mapress fitting; copper or stainless steel.

**The fitting type may differ slightly for different manufacturers, i.e. it is a good idea to check which tong series should be used for the specified pressfitting.**



### Equipment for which jaws are to be ordered separately:

Product category	Name	Tongs	Weight
660012	Pressfitting tool REMS Mini-Press ACC	M12-M28	2,5 kg
	Pressfitting tool REMS Battery-press ACC	M12-M35	4,5 kg
330252	Mapress tongs for REMS machines (To be ordered separately)	M12 M15 M18 M22 M28 M35	0,5 kg/kpl



### Complete tool package with tongs

Product category	Name	Tongs	Unit weight
330253	ROMAX 4000	M15; M22; M28; M42; M54	4 kg



### PORTABLE COLLARING MACHINES

- With a portable collaring machine, you can make joint holes in unpressurised pipelines.
- Operating power: 230 V

Product category	Name	Pipe	Aperture
650100	T-30	Copper	10-35 mm

### HOT TAPPING MACHINES

For making interventions in large and small pressurised pipelines.

**Blades sold separately**

Power 220 V



Product category	Name	Threaded sleeves	Max. pressure	Weight
331100	Tonisco B30	DN80, DN100, DN150, DN200	40 Bar	32 kg
331100	Naval	DN25, DN32-40, DN50, DN65, DN80, DN100	25 Bar	15 kg
331100	NoTap Tiger Tee	DN20, DN25	16 Bar	5 kg
331100	NoTap Tiger Big	DN40, DN50, DN65	16 Bar (DN65 10 Bar)	10 kg



### PIPE DRILLING STAND

Drill not included. We recommend using a variable speed drill, such as the Metabo BE75-16 or Metabo 622.

Product category	Pipe size	Max. hole size	Weight
330000	21,0 - 273 mm (½-10")	125 mm	8 kg

### ELECTRIC PIPE FREEZER

Easy-to-use 230V pipe freezer for such applications as replacing radiators.



Product category	Name	For pipes Ø	Weight
330100	RoFrost Turbo2	Kupari: 12 mm, 14/15 mm, 18 mm, 22 mm, 28 mm, 42 mm, 54 mm Rauta: ¼", ⅜", ½", ¾", 1¼", 1½"	26 kg



## HOLE CUTTING TOOL FOR PIPES



The HC450 is designed for continuous ¼" (6 mm) to 4 ¾" (120 mm) hole cutting in up to 8" (203 mm) diameter unpressurised steel pipe. The built-in level ensures line up for multiple holes when branching lines. Dual handles and controls makes work easy on both sides.

Blades sold separately

Product category	Name	Speed	Output	Pipe	Blade ø
860206	HC 450	110 kier/min	1800 W	1 ¼"-8"	6-16 mm

## THREADING MACHINES

For use in such applications as sprinkler installation.

Remember to use cutting fluid and discharge the tanks before returning.



Product category	Name	Pipe	Speed	Operating	Weight
330804	Ridgid 690, incl: <ul style="list-style-type: none"> <li>• 65560 - 3/8" BSPT</li> <li>• 65570 - 3/4" BSPT</li> <li>• 65575 - 1" BSPT</li> <li>• 65580 - 1 1/4" BSPT</li> <li>• 12553 - 1 1/2" BSPT</li> <li>• 12558 - 2" BSPT</li> </ul>	1/8" - 2"	30 rpm	230 V	10 kg
330801	Ridgid 535 - 2B (Comes without threading die)	1/2" - 2"*	35/70 rpm	400 V	120 kg
330800	Compact 300 with legs (Comes without threading die)	1/2" - 2"	38 rpm	230 V	60 kg
<b>Threading dies for the Ridgid 535 and Compact 300 (blades sold separately)</b>					
Tuote: 881000000112	Die head (Ridgid 535 & 300)	1/2" - 3/4"			
Tuote: 881000000111	Die head (Ridgid 535 & 300)	1/4" - 3/8"			
Tuote: 881000000113	Die head (Ridgid 535 & 300)	1" - 2"			
Tuote: 92140100000x	Ridgid 141 (Ridgid 535-2B)	2 1/2" - 4"			
Tuote: 921401000012	Ridgid 161 (Ridgid 535-2B)	4" - 6"			

\* With receding geared threaders 141 or 161





## GROOVING TOOLS

Designed to make grooves near pipe ends for mechanical joiners

Product category	Name		Pipe	Pipe thickness	Weight
330600	GROOVER 10A/10B	220 V	33,7 - 219 mm	1,8 - 2,9 mm	107 kg
330601	VICTAULIC VE26S	Manual	54 - 155 mm	1,7 - 5,5 mm	10 kg

## MECHANICAL PIPE BENDERS



**Manually operated (for stainless steel, copper, brass, aluminium, etc.)**

Product category	Name	Pipe outer ø	Wall thickness	Weight
921379000000	MINOR-BEND	4 - 18 mm	0,5 - 2 mm	2,5 kg
921380000000	BIG-BEND	10 - 32 mm	0,5 - 2 mm	11 kg
921381000000	SUPER-BEND	16 - 42,2 mm	1 - 2 mm	23 kg
921414000000	PIENI QUICK BEND	3/8" - 3/4" / 6-32 mm	2-4 mm	7 kg

## ELECTRIC PIPE BENDERS

Compact, lightweight pulse inverter machines for light-duty work on job sites. Designed for the bending of copper pipes. Former data shown in the table below.



Product category	Name	Weight
330201	Rems Curvo 40 220V	8 kg (24 kg)
Formers + back	Name	ø + R
330220	Former + back former	32 mm R114 (6, 7) 28 mm R102 (2, 4, 5) 25 mm R98 (4, 6, 7) 22 mm R77 (1, 2, 4) 20 mm R75 (1, 3, 6, 7) 18 mm R70 (1, 2, 4, 5, 7) 15 mm R55 (2, 3, 4) 12 mm R42 (2, 4)

1. Cu-U: Coated copper
2. St 10312: Stainless steel tubes for pressfitting systems EN10217-7
3. St 10305-U: Soft carbon steel tubes for pressfitting systems EN 10305-3
4. St 10305: Soft seamless steel pipe EN 10305-1 / -2 / -3
5. St 10255: Welded steel pipes (threadable) EN 10255
6. St 50086: Electric conduit DIN EN 50086
7. V: Multi-layer composite tubes for pressfitting systems

## LARGE MANDREL PIPE BENDERS



Product category	Name	Pipe max. Ø*	Weight	Further information
330205	Mackma BM 48/400V	Ø 48 x 4 mm (1½")	110 kg	Rollers underneath Bending from both sides IP21
330223	Formers**	Back former (AIBR)	Back former (normal)	
	½" (R56 / R67)	923665000000	923660000000	
	¾" (R85)	923666000000	923664000000	
	1" (R90 / R112 / R130)	923667000000	923661000000	
	1½" (R150 / R170)	923669000000	923663000000	
	1¾" (R130 / R150)	923668000000	923662000000	

\* For the following material thicknesses: UNI FE -42 kg/m<sup>2</sup> 48 x 3,5 mm; FE 35 kg/m<sup>2</sup> 48 x 4 mm; AISI 304/316 - 65 kg/m<sup>2</sup> 48 x 2 mm

\*\* Example formers. Please check availability from your local Ramirent.



Product category	Name	Pipe max. Ø	Weight	Further information
330205	JUTE6000	Ø 60 x 5 mm	110 kg	Ask for availability



Product category	Name	Pipe max. Ø*	Weight	Further information
330205	Ercolina TOP-Bender	Ø 60 x 4 mm (2")	180 kg	Shipped without formers.
330221	Lesti + luisti paketti	½" -2" (R56-R260)	2-10 kg	Ask about availability for different

\* AISI 304-316 60 x 3 mm; Standard steel/Gas tuber 60 mm (2") x 4 mm

## HYDRAULIC PISTON OPERATED PIPE BENDERS



Name	Power	Weight	Pipe size	Formers
Toka 90 400V	15 kN	90 kg	3/8" - 3 1/2"	3/8" 1/2" 3/4"
Klaeger BE 400V	10 kN	90 kg	max. 2"	1" 1 1/4" 1 1/2" 2"

## LARGE PIPE BEVELLING MACHINES

Beveling machines for the precise beveling of pipes, such as for boiler work. Blades sold separately.



Product category	Name	For pipes	Weight	Further information
330006	Wachs SF1016/3	10-16" , 254-406 mm	35 kg	Blades sold separately Also requires a hydraulic unit.
	Wachs SF1420/3	14-20" , 355,6-508 mm	42 kg	Blades sold separately Also requires a hydraulic unit.
230017	Hydrauliyksiköt		60-160 kg	Power unit for Wachs machines.



Product category	Name	For pipes	Weight	Further information
330006	Ridgid B-500	<ul style="list-style-type: none"> <li>3 1/2" (100mm) and larger pipes</li> <li>Wall 0,18"-1/2" (4,8-12,7mm)</li> </ul>	24 kg	Available in 3 angles: 37,5°, 30° r 45° (6 blades per set)



Product category	Name	For pipes	Weight	Further information
330007	Wachs 424	4-24" 101,6 - 609,6 mm	100 kg	Blades sold separately Inner mount (96-508 mm). Pneumatic.

## SMALL TUBE AND PIPE BEVELERS

- For bevelling the outside end of a pipe without cutting
- Pneumatic (6 bar)
- Blades sold separately.
- Also available in other sizes

Product category	Working range (I.D.)	Clamp rib	Machine length	Weight
WACHS CB BOILER BEVELER	12,7 - 60,4 mm	Outer surface	310 mm	29 kg
MILLHOG TW-200	25,4-76,2 mm	Inner surface	368,3 mm	8,2 kg
MILLHOG H-300 WART	32-114 mm	Inner surface	368,3 mm	8,7 kg
MILLHOG P-300 PREPZILLA	40-219,1	Inner surface	501,7 mm	18,2 kg
FUJI FBM 120	45 - 240 mm	Inner surface	518 mm	24 kg

HHB-10



Tube Weasel



Prepzilla



Wart



## PIPE CUTTING

- Mechanical cutting
- Advantages: cutting without sparks or shavings
- Available with different blades for cutting stainless steel, cast iron and steel pipes



Product category	Name	Pipe size	Weight	Further information
660010	S-44	2½" - 4" (65-100 mm)	9,1 kg	4 blades 100956302013 (lade separate)
923030000000	1-A	1½" - 1¼" (3-32 mm)	3 kg	1 blade
923030000005	S-6	4" - 6" (100-150 mm)	10 kg	1 blade
923030000004	468-S	6" - 8" (150-200 mm)	15 kg	4 blades. Hinged mount
660009	246	2" - 12" (50-300 mm)	11,3 kg	Brick cement, cast iron drainpipes (34575 chain)

## PIPE SAWS



EXACT 220E

The PipeCut 220E offers high performance and a wide cutting capacity. It can be used for the cutting of metal and plastic pipes. The PipeCut has an adjustable motor speed and constant torque.

Blades sold separately.

Blades: Stainless steel/plastic/copper: 100956301069 FE 140x62 mm

Cast iron: 100956301071 FE 140x62 mm



<b>Product category</b>	330503
<b>Pipe size</b>	Ø 15-220 mm
<b>Input power</b>	1200 W
<b>Voltage</b>	230 V
<b>Wall thickness</b>	6 mm steel 14 mm plastic
<b>Included</b>	4 kpl supports
<b>Weight</b>	6 kg

## IPE RECIPROCATING SAWS

Product category	Name	Power	Capacity	Weight	Further information
13023	Ridgid 550-1 (230V)	1200W 800-2,400 rpm	Steel plate 4" Steel plate 1/4" Wood 120 x 112 mm	3,2 kg	Includes chain - clamp



### Blades sold separately

Blades	Name	Use	Size
100956301024	D1006	General + stainless steel	6" / 150 mm
100956301023	D1004	Thick walled metal	6" / 150 mm
100956301025	D1005	Thick walled metal	8" / 200 mm

## ORBITAL CUTTING

- No cutting fluid
- Straight cutting head
- Blades sold separately



Blades: Cobalt HSS 16 mm  
 LS8034: 5-12 mm  
 LS9038: 5-15 mm

	AXXAIR CC122	AXXAIR CC172	AXXAIR CC320
<b>Product category</b>	330500	330501	330502
<b>Outer dimensions of pipe</b>	5 - 120 mm (1 - 4,5")	16 - 170 mm (0,63 - 6,63")	140 - 330 mm
<b>Wall thickness</b>	0,7 - 15 mm	0,8 - 15 mm	1,5 - 15 mm
<b>Weight</b>	pprox. 44 kg	68 kg	114 kg

## PIPE CENTERING EQUIPMENT



Pipe centering chain			
Product category	For pipes	Weight	
330400	<410 mm	32 kg	Chain
	<440 mm	36 kg	Chain
	<470 mm	40 kg	Chain
	<600 mm	45 kg	Chain
	<850 mm	55 kg	Chain
	<910 mm	63 kg	Chain
	<100 mm	65 kg	Chain
	127-610 mm	45 kg	Chain



Centering collar			
Product category	For pipe	Weight	
330408	DN/NS100	2 kg	Collar
	DN/NS125	4 kg	Collar
	DN/NS150	6 kg	Collar
	DN/NS250	8 kg	Collar
	DN/NS300	12 kg	Collar
	DN/NS350	12 kg	Collar
	DN/NS400	14 kg	Collar
	DN/NS500	16 kg	Panta
330407	DN/NS600	20 kg	2 Collars
	DN/NS900	24 kg	2 Collars
	DN/NS1000	26 kg	2 Collars

Collar tightener for the centering collar	
Product category	
330409	Collar tightener (2 ill be needed if there are 2 ollars)

### PIPE CENTERING CLAMP



Product category	Range (inches)	Range	Weight
330401	1-3"	25-80 mm	1,5 kg
330402	2-5"	50-140 mm	3,1 kg
330403	4-9"	120-250 mm	6 kg
330404	10-14"	225-370 mm	9 kg

### PRESSURE TEST PUMPS

- Can be used with water, oil (SAE30) and ethylene glycol
- Shipped with 5-20 m hoses



	RIDGID 1460E	RIDGID 1450	FF1521K	FF1515K
Product category	300902	330900	300901	300901
Pressure	60 Bar	50 Bar	350 Bar	500 Bar
Tank volume	12 l steel	13,5 l	Connection 1/2" inlet 0,3-10 Bar (70 C)	Connection 1/2" inlet 0,3-10 Bar (70 C)
Power	220 V	Manually-operated	400 V	400 V
Output	9 l/min	38 cm <sup>2</sup> / stroke (2 speed)	21 l/min	15 l/min
Weight	20 kg	6,5 kg	140 kg (wheels)	150 kg (wheels)

### DRAIN CLEANING EQUIPMENT

Sectional machine (Product category 331000)



- Compact and versatile machine for professional use. The perfect, all-around sink, shower and floor drain machine. Weighs less than 18 kg.
- Unique, easy-to-use, instant-acting cable clutch maximizes operator control: Pull handle down and cable spins at 400 RPM. Release handle, cable stops instantly.
- Included:
  - A-30 cable kit: T-201 Straight auger T-202 Bulb auger T-205 "C" cutter T-211 Spade cutter A-13 Coupling pin key A-10 Cable carrier A-14-6 Rear guide hose.
  - 2,3m (16mm) cable
  - Best suited for cleaning 32-75mm lines



---

## PIPE BUTT WELDING ROWELD 355



- Easy-to-use unit for but welding drain pipes.
- For 160-355 mm pipes
- Robust inserts, welding mirror, hydraulics 4 rollers, leveller (Rocut 355 pipe saw available separately)
- Weight: 120 kg (complete set)

---

## ELECTROFUSION WELDING UNIT ATS250



User-friendly unit for the electrofusion welding of pipes.

- Product category: 330801
- Automatic electrofusion welding unit equipped with a bar code reader. The welding unit is designed for the welding of PE and PP pipe joints in bar code mode at a constant voltage between 8 and 48 volts.
- 220 V, 20 kg, 22 x 26 x 45 cm

---

## STEELFLEX PIPE TRAILER JPV 1500



<b>Product category</b>	30433
<b>Total weight</b>	1500 kg
<b>Pull/push force</b>	200 kg
<b>Max. outer diameter of the pipe stack</b>	2450 mm

Flex pipe trailers have been primarily developed for the handling of bendable pipes delivered in 100m stacks. The trailer can easily accommodate a 100-metre stack of flex pipe. Pipe is run through a pulling device, which simultaneously straightens the pipe. All key trailer functions are hydraulic and the hydraulic power source is a Honda combustion engine.

# TORQUE TOOLS

## HYDRAULIC TORQUE WRENCHES POWERED BY A SEPARATE PUMP

TWHC High Cycle Torque Wrench & TWLC Low Clearance Torque Wrench



- **Corrosion-resistant** materials can withstand even the harshest conditions.
- **Compact nose radius** allows the tool to fit into tight spaces.
- **Long stroke** accelerates work.
- **Swivelling hydraulic manifold** allows the tool to rotate 360° + 180° to the site.
- **A locking square drive** allows the tool to be used on both sides. It can be pushed through and locked with a push button.

Order no.	Square drive	Torque max. max. 700 bar*	Weight, kg
TWHC1	3/4"	1915 Nm	2,8 kg
TWHC3	1"	4249 Nm	5,3 kg
TWHC6	1-1/2"	8189 Nm	8,8 kg

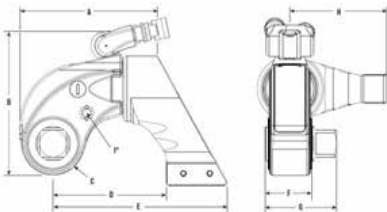

Order no.	E-D reaction arm from square drive	B (incl. R) total depth	C body radius	F body height	H reaction arm height
TWHC1	170-112	145	28	39,5	87
TWHC3	197-129	173	36	53	105
TWHC6	243-158	201	44	61	136

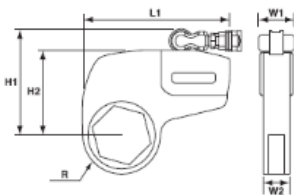

Order no.	Hex. range	Torque max. 700bar*	L1 body length	H1 (incl. R) total depth	R body radius	W1 max. height	W2 link height	Weight
TWLC4	60 mm+ 55 mm sovite	5386 Nm	223	130	37-59	52	42	5,7

\*In the pump pressure range 100-700 bar, the ratchet torque has a repeat accuracy of +/-3%. (Even though Power Team TW pumps can be adjusted within a range of 20-700 bar, the repeat accuracy of the ratchet is not necessarily within a reading of +/-3% <70bar).

## ELECTRIC PUMPS FOR HYDRAULIC WRENCHES PE55 - PE45 AND PE35

TWHC High Cycle Torque Wrench & TWLC Low Clearance Torque Wrench

- Twin hose (5-8 m) included
- Easy-swap 100 mm pressure gauge.
- Detachable remote control unit (5 m cable).
- Starts at 20% below the rated nominal voltage.
- Easily adjustable external pressure regulator. 103 bar retract side internal relief valve to protect tool.
- Continuous operation in a 50-degree environment.



Order no.	Description
PE55-TWP-E220 CE-approved	Basic pump like the PE55-E220, which is equipped with a 4-way, 2-position solenoid valve for ratchet operation - 0.84kW - 13A230V - 12,000 rpm – 92>87dB, output 11.5 - 0.9 l/min - starts at 60% of the nominal voltage; will run when using extension cords - Usable oil capacity: 5.3l; aluminium reservoir w/ oil level/thermometer and oil discharge port - Weight: 34 kg, with oil and accessories
PE39PED1PR CE-approved	The PE39 is a compact and highly portable pump, which offers exceptional performance for a unit of its size. <b>Can be used vertically and horizontally.</b> - 1.3 HP Universal motor (230V– 50/60 Hz 7.2A) -> 87-92 dB - Output: 3.7l/min – 0.64 l/min - Weight: 17.7kg (w/o oil). - 1.9 l hydraulic oil/ 1.5 l usable oil capacity - Detachable, calibratable 100 mm gauge  Separate cooler with fan
PE45PEE4PRS	<b>The 2-speed PE45 pump provides continuous pressure (from low to high pressure stage) for up to two times the speed of typical 2-stage pumps!</b> - Improved oil filtration - 1.8 HP Universal motor (230V – 50/60 Hz 8.5A) -> 87 – 92 dB - Output: 9.4 l/min – 0.8 l/min - Weight: 32kg - Oil: 6.75 l / Usable oil capacity: 5.1 l  Separate cooler with fan

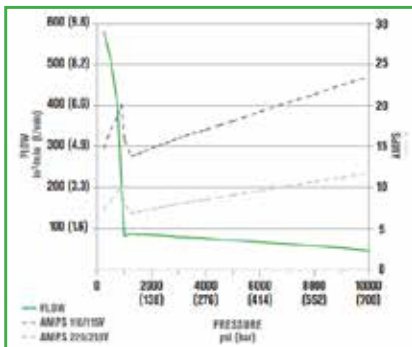

PE55

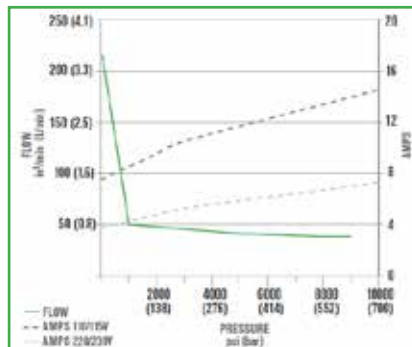

PE39

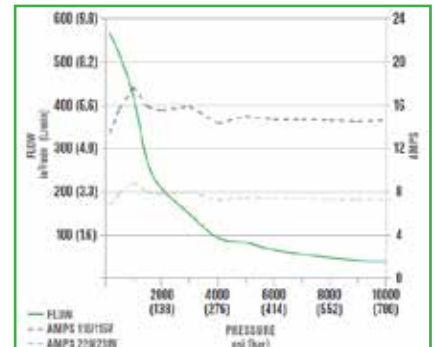

PE45

## ELECTRIC AND BATTERY-OPERATED TORQUE WRENCHES

If you need to loosen or precisely torque a few bolts, we recommend using one of our hydraulic, non-impact torque wrenches



### Electrical

Product category	Name	Square	Torque	Speed	Weight
660502	JUWEL TES-351	1 1/2"	360 - 3500 Nm	8 rpm	10 kg
	JUWEL TES-241	1"	430 - 2500 Nm	9 rpm	9 kg
	NORBAR ET-92	1"	800 - 4000 Nm	6 rpm	13 kg



### Battery-operated hydraulic torque wrenches

Product category	Name	Square	Torque	Speed	Weight
660502	B-RAD 4000	1"	800 - 4000 Nm	2 rpm	6 kg

## IMPACT WRENCHES



Product no.	Name	Square	Torque/ max. bolts	Power	Vibration	Weight
9012	KPT-14ME	1/2"	560 Nm	Pi: 10,10 l / s (1/4" coupling)	3,2 m/s <sup>2</sup>	2 kg
9013	NW-2000H	3/4"	1300 Nm	Pi: 20 l/s (1/4" coupling)	4,5 m/s <sup>2</sup>	4 kg
9014	IR 2925RBP3TI	1"	407-1288 Nm* (2169Nm)	Pi: 28 l/s (3/8")	10,5 m/s <sup>2</sup>	5,5 kg
9015	IR 2950BE	1 1/2"	3169-3390 Nm* (4067 Nm)	Pi: 33 l/s	12 m/s <sup>2</sup>	15 kg
10416	DTW 251RFE	1/2"	230 Nm / M16 (M14)***	Battery	11 m/s <sup>2</sup>	1,5 kg
10417	DTW 450 RMJ	1/2"	450 Nm / M22 (M16)***	Battery	19 m/s <sup>2</sup>	3,4 kg
10417	DTW1002RTJ	1/2"	300 Nm; 600 Nm; 1000 Nm** / M30 (M24)***	Battery	18 m/s <sup>2</sup>	3,6 kg
10405	BOSCH GDS 30	1"	1000 Nm / M30	220 V	4 m/s <sup>2</sup>	7,3 kg
10406	BOSCH GDS 24	3/4"	600 Nm / M24	220 V	4 m/s <sup>2</sup>	5,7 kg
10407	BOSCH GDS 18 E	1/2"	70-250 Nm / M18	220 V	4 m/s <sup>2</sup>	3,2 kg

\* Manufacturer's recommended torque

\*\* 3-stage power selection

\*\*\* High strength bolts

## TORQUE MULTIPLIERS



Product category	Name	Square	Torque	Weight
660501	NORBAR 25:1	1/2" - 1"	200 - 3400 Nm	10 kg
	NORBAR 5:1	1/2" - 3/4"	1300 Nm	7 kg
	BRITOL 5:1	3/4" - 1"	2800 Nm	7,2 kg

## TORQUE WRENCHES



Product category	Name	Square	Torque	Weight
660505	NORBAR 1500	1"	550 - 1500 Nm	7 kg
660504	STAHLWILLE 721	3/4"	160 - 800 Nm	6 kg
660503	STAHLWILLE 730/10	1/2"	20 - 100 Nm	2 kg
	730/20		40 - 200 Nm	
	730/40		80 - 400 Nm	

## IMPACT SOCKETS AND ADAPTERS



We carry the necessary sockets for torque tools:

- Impact sockets (short and long) 17-100mm
- Adapters 1/2 - 1 1/2"

---

**STRIKING FACE BOX SPANNERS**



24 mm, 27 mm, 30 mm, 32 mm, 33 mm, 36 mm, 41 mm, 46 mm, 50 mm, 55 mm, 60 mm, 65 mm, 70 mm, 75 mm, 80 mm, 85 mm, 90 mm, 95 mm

---

**STRIKING FACE BOX END WRENCHES**



24 mm, 27 mm, 30 mm, 32 mm, 33 mm, 34 mm, 36 mm, 41 mm, 46 mm, 50 mm, 55 mm, 60 mm, 65 mm, 70 mm, 75 mm, 80 mm, 85 mm, 95 mm, 100 mm, 105 mm, 110 mm

---

**COMBINATION WRENCHES**



24 mm, 27 mm, 30 mm, 32 mm, 36 mm, 38 mm, 41 mm, 46 mm, 50 mm, 55 mm, 60 mm, 65 mm, 70 mm, 75 mm

---



**ADJUSTABLE WRENCH 18-30"**



# WELDING EQUIPMENT

## TIG WELDING MACHINES

All TIG welding machines are equipped with the Minilog function and come with a remote control, pressure regulator, soldering iron + electrode, earth return cable and electrode holder.

	Product category	Name		Electrode	Further information	Weight
	300115	Kemppi MinarcTig 200MLP	230 V 5,6 kVA	1,5 - 4 mm	200 A (35%*) Electrode: 170 A (35%*) Length of included cables 10 m	11 kg
	300102	Kemppi Master 2300 AC/DC	230 V 8 kVA	1,5 - 4 mm	230 A (40%*) Puikko: 180 A (40%*) Length of included cables 5 m	15 kg
	300110	Kemppi Master 3000MLS* (MTM-paneeli)	400 V	1,5 - 5 mm	TIG: 300 A (30%*) Electrode: 250 A(40%*) Length of included cables 20 m. Torch 15 m. Comes on a cart.	22 kg
	300111	Kemppi Master 4000MLS*	400 V	1,5 - 6 mm	TIG: 400 A (40%*) Electrode: 350 A (35%) Length of included cables 20 m. Torch 15 m. Comes on a cart.	23 kg

\*\* The load factor indicates the percentage at which it is possible to weld for a 10-minute period at the given current without causing the machine to overheat (at a temperature of 40C°).

## WATER COOLERS FOR TIG MACHINES

	Product category	Name		Power	Further information	Weight
	300310	Kemppi Mastercool 10	400 V	1,0 kW	MLS-Tig elding machines	10 kg



## MIG-WELDING MACHINES

### Machines with separate wire feed and optional water cooling



Product category	Name		Further information	Weight
300033	<b>Power source:</b> Kemppi Fastmig M 420	400 V 20 kVA	420A (60%) MR300 panel Included: Cart, welding cable 10m, MIG torch (PMT 42W) 4,5 m	35 kg
300307	<b>Wire feeder:</b> Kemppi Fastmig MXF 67	400 V	Speed: 0-25 m/min. Wire reel: max. 300 mm/20 kg, Fe, Ss: 0,6 - 1,6 mm. Filler wire: 0,8 - 2 mm. Al: 1 - 2,4 mm	12,5 kg
300311	<b>Water cooler:</b> Fastcool10	400 V	Power: 1 kW Tank: 3 l	11 kg



Product category	Name		Further information	Weight
300033	<b>Power source:</b> Kemppi Pro 4200 Evolution	400 V	420A (70%*) MC panel Included: Cart, welding cable 10m, MIG torch (4,5 m)	41 kg
300039	<b>Power source:</b> Kemppi Pro 5200 Evolution	400 V	520 A (70%*). MXE panel (synergic). Included: Cart, welding cable 10 m, MIG torch (4,5 m)	48 kg
300307	<b>Wire feeder:</b> Kemppi Promig 530	400 V	Speed: 0-25 m/min. Wire reel: max. 300 mm/20 kg, Fe, Ss: 0,6 - 1,6 mm. Filler wire: 0,8 - 2 mm. Al: 1 - 2,4 mm	21 kg
300311	<b>Water cooler:</b> Kemppi Procool 30	400 V	Tank: 3 l 120W	12,5 kg

\*\* The load factor indicates the percentage at which it is possible to weld for a 10-minute period at the given current without causing the machine to overheat (at a temperature of 40C°).

### Mig-welding machines with wire feeder



Product category	Name		Further information	Weight
423	Kemppi Fitweld 300	400 V 11,kVA	300A (20%*) Wire reel: max. 200 mm Fe, Ss: 08 - 1,2 mm, Al: 1 - 1,2 mm. Included: MIG torch MMT (4,5 m), welding cable 5 m	14,5 kg
300308	Kemppi Kempact pulse 3000	400 V 18kVA	250 A (40%*). Synergic. Fe (solid): 0,6 - 1,2 mm Fe (fill): 0,9 - 1,2 mm, Al, CuSi: 0,8, 1,2 mm	22 kg

\* The load factor indicates the percentage at which it is possible to weld for a 10-minute period at the given current without causing the machine to overheat (at a temperature of 40C°).

## MANUAL METAL ARC (MMA) WELDING MACHINES

Manual Metal Arc (MMA) welding machines come with earth return and welding cables (3-5 m) Extensions also available.



Product category	Name		Electrode	Further information	Weight
300001	Esab Caddy	230 V	1,6 - 3,25 mm	140 A (35%*)	6 kg
300004	Kemppi Minarc 150	230 V 7,5 kVA	1,5 - 3,25 mm	150 A (35%*)	5 kg
300006	Kemppi Minarc EVO180	230 V 5,7 kVA	1,4 - 5 mm	170 A (30%*) Included: remote control 5 m	5 kg
300030	Kemppi Master 3500MLS	400 V 15 kVA	1,5 - 6 mm	350 A (40%*) Included: remote control 20 m kaapelit	21 kg
300040	Kemppi Master S400	400 V 20 kVA	1,6 - 6 mm	400 A (60%*)	20 kg

\* The load factor indicates the percentage at which it is possible to weld for a 10-minute period at the given current without causing the machine to overheat (at a temperature of 40°C).

## STORAGE AND DRYING OF WELDING ELECTRODES



### ESAB PK5 Dryer and dry storage system

The PK 5 is a combined drying and dry-storage system for most types of electrodes. The drying time at full power is 1-7 hours, depending on the type of electrode. Adjustable storage temperature: 70-300°C.

### ESAB PK1 dry storage system

The PK 1 is a portable dry-storage container for electrodes. Storage temperature: approx. 100°C.



### ESAB PK 410 drying cabinet

The PK 410 is a robust cabinet for the drying and dry storage of electrodes. The PK 410 is equipped with a control lamp, electronic thermometer and electronic thermostat.

### ESAB SK 40 dry storage cabinet

The SK 40 is a dry-storage cabinet for storing electrodes. The cabinet is equipped with a thermometer, thermostat and control lamp. Adjustable storage temperature: 50-180 °C.



Product category	Name	Use	Temperature	Capacity	Weight
300407	PK-1	Storage	100-110 C	1,5 packages	6 kg
300406	PK-5	Storage and drying	50-300 C	approx. 3	13 kg
300408	PK-410	Storage and drying	50-400 C	approx. 40	230 kg
300409	SK-40	Storage	50-180 C	approx. 20	55 kg

## SMOKE EXTRACTORS

The Carryvac 2 P150 and P150 AST are compact, lightweight and portable welding smoke extractors, which are exceptionally well suited for maintenance welding in light and medium-duty applications.

When the Carryvac 2 unit is connected to the extraction nozzle, it extracts the smoke directly from the source. The polluted air is filtered and contained in a hygienically packed filter.



Product category	Name		Further information	Weight
300404	Carryvac 2 P150	230 V	Filtration efficiency 99,7% 75dB Hose ø 45mm x 7m + 200 mm wide nozzle Filter volume (ilter 0700 003 004): n.200 kg Marathon Pac wire or twelve 15 kg welding wire reels.	14,5 kg
300404	Plymovent	230 V	Without filter 2400 m <sup>2</sup> /h 69 dB Hose attachment ø 160 mm	17 kg

## GAS WELDING EQUIPMENT

Product category	Name	Further information
92139000000	Flame cutting, set X-11 hoses Oxygen/Acetylene Gauges and handles	<ul style="list-style-type: none"> <li>Handle X11 Ergonomic</li> <li>10-20 m hoses + gauges (oxygen/acetylene)</li> </ul>
05051000000	Kosan/LPG torches: Sievert Pro88 (Trigger handle + control valve, footstand, connector, hose (4m), 350mm neck tube, Ø35 Pro brass burner)	<ul style="list-style-type: none"> <li>Available with pressurised (2 bar) or threaded connectors (allows full output 4 bar).</li> </ul>
921393000000	Oxygen/LPG hose - package	<ul style="list-style-type: none"> <li>Hoses 10-20 m, gauges, handles (Harris 43-2)</li> </ul>
921708000000	Heating tip tube 710 mm	<ul style="list-style-type: none"> <li>Hoses 10-20 m, gauges, handles and burner (AGA X21 + cutting attachment 90)</li> </ul>
921391000000	AGA X21 torch system	<ul style="list-style-type: none"> <li>Hoses 10-20 m, gauges, handles and burner (AGA X21 + cutting attachment 90)</li> </ul>
921392000000	AGA X11 tube set	<ul style="list-style-type: none"> <li>AGA X11 Pro Plus tube set (excl. handle)</li> <li>Cutting attachment 90 deg.</li> <li>Neck tubes 160/315/500/800 l</li> <li>Multi-flame burner 1000 l</li> <li>Cutting nozzles HA411-2/HA411-3</li> <li>Cleaning needle kit</li> <li>Cutting support</li> <li>Gas igniter</li> <li>Case X11</li> </ul>





## GAS CYLINDER TRUCKS

Product category	Name	Further information	Weight
300420	Gas cylinder truck 2x20 l		20 kg
300421	Gas cylinder truck 2x40 l	Lifting bracket max. 250 kg. Supply box Solid and pneumatic tyres.	40 kg

## PLASMA CUTTING



Product category	Name	Requirements	Capacity	Further information	Weight
300500	PowerCut 1500	400 V Air: 170 l/min 5,2 Bar	Cuts 1½" /34mm	90A (60%) Included: Wheel kit Earthing cable PT-32EH torch (7m)*: Elektrode 100953401003 Nozzle 40A 100953401004 Nozzle 90A 100953401005 Heat shield 100953401007	43 kg
300500	PowerCut 1600	400 V Air: 236 l/min 6,2 Bar	Cuts 1½" /34mm	90A (60%) Included: Wheel kit Earthing cable PT-32EH torch (7m): Elektrode 100953401003 Nozzle 40A 100953401004 Nozzle 90A 100953401005 Heat shield 100953401007	41 kg
300500	Shark105	400 v Air: 280-330 l/ min 5-6 bar	Cuts max. 35 mm	90A (60%) Torch 812 m)	24 kg

\* A fee will be charged if the equipment is returned in poor condition.



### HOT-AIR TOOL

Product category	Name	Power	Heating	Weight
434	Leister Triac / 230 V	1600 W	45-600 °C	1 kg

Suitable for use in such applications as welding seams on plastic flooring.



### WELDING TENT

Welding tents shield the job site from the surrounding area and protect the environment from the effects of welding. Separate work/trench tents are also available for grid construction.

Product category	Name	Size (L x W x H)	Head	Note!
520004	CEPRO	2,0 x 1,9 x 2,2 m	26 kg	Assembly required Frame made of strong galvanised tubing (Ø 25 mm)
520004	PA180	1,8 x 1,8 x 2,0 m	13,5 kg	“POP-UP” ssembly. No separate poles.



### PERSONAL GAS DETECTION INSTRUMENTS

Small handy Dräger Gas Detectors have been designed for industrial environment with users.

Product category	Name	Gas	Measuring range	Accuracy
841307	Dräger Pac 5500	H2S	0-100 ppm	0,1 ppm
841325	Dräger X-am 2500	Ex O2 H2S CO	0-100% LEL 0-20% 0-100 ppm 0-2000 ppm	5% LEL 0,3% 2% 3%

### EUMATIC CHIPPING HAMMERS AND NEEDLE SCALERS



Product category	Name		Head	Blow rate	Weight
300417	Debrag SN10 (pistol)	Compressed air 0,15 m <sup>3</sup> /min (R <sup>3</sup> / <sub>4</sub> ) approx. 6,3 Bar	Needle: 29pcs 2x150 mm	4000	1,4 kg
300417	Fuji FCH-25B-1F (straight)	Compressed 0,18 m <sup>3</sup> /min (R <sup>1</sup> / <sub>4</sub> ) approx. 6,3 Bar	Chisel	7000	1,6 kg



## WELD PURGE MONITORS

Product category	Name		Precision	Weight
300415	Purgeye 100 (2 m hose)	Battery	Measurement range: 20,94% - 0,01% (100 ppm) Oxygen level 20%= ±0,2% Oxygen level 2%= ± 0,02%	1 kg

Measures the oxygen concentration in the workpiece in order to ensure a high-quality weld.



**Shielding gas plug sets are also available (50-400mm)** incl. diffuser, 2 x 2 sheets for large and 2 x 4 sheets for small.

## TUNGSTEN ELECTRODE GINDER



Small handy tool for grinding and cutting tungsten electrodes.

Product category	Name	For electrodes	Weight
300423	Litty Power Pointer / 220 V	1,6 mm / 2,4 mm / 3,2 mm	1 kg





# FIBRE OPTICS TOOLS

## FUSION SPLICERS



Product category	Name	Welding	Oven	For optical fibres/Damping	Comes in a carry case, which contains:
<b>Core alignment</b>					
700000	Fujikura 70S	7 sek	14 sek	Single/SMF (G.652/657) / 0,02dB MMF (G.651) / 0,01dB DSF (G.653) / 0,04dB NZDSF (G.655) / 0,04dB	Included: Optical fibre cutter** Strippers 2 batteries Electrodes
700000	Fujikura 62S	6-10 sek	15-23 sek	Single/SMF (G.652/657) / 0,02dB MMF(G.651) / 0,01dB DSF(G.653) / 0,04dB NZDSF(G.655) / 0,04dB	Included: Optical fibre cutter** Strippers 2 batteries Electrodes
700000	Inno View 5	7-9 sek	13 sek	SM (ITU-T G.652&G.657) / 0,02dB MM (ITU-T G.651) / 0,01dB DS (ITU-T G.653) / 0,04dB NZDS (ITU-T G.655) / 0,04dB	Included: Optical fibre cutter** Strippers 2 batteries Electrodes
700000	Fujikura FSM-60S	9 sek	30 sek	Single (ITU-TG.652) / 0,02dB MMF (ITU-T G.651), 0,01dB DS (ITU-T G.653), / 0,04dB NZDS (ITU-T G.655) / 0,04dB	Included: Optical fibre cutter** Strippers 2 batteries Electrodes
<b>V-groove alignment</b>					
700004	Fujikura 12S*	15 sek	30 sek	SMF(G.652/657) / 0,05dB MMF(G.651) / 0,02dB DSF(G.653) / 0,08dB NZDSF(G.655) / 0,08dB	Included: Optical fibre cutter** Strippers 2 batteries Electrodes

\* Passive V-groove alignment is done mechanically using static V-grooves. Because the unit can only move optical fibre longitudinally, precision is adequate for such applications as property installations.

\*\* Separate optical fibre cutters also available (700002), if the job requires multiple cutters.



## OTDR INSTRUMENTS



Product category	Name	Wavelengths	Dynamics	Weight
700020	FTB-200 + FTB7300	1310 / 1550 nm	38/34 dB (max. 260 km)	2,1 kg
700020	FTB-200 + FTB7200	1310 / 1550 nm	35/34 dB (max. 260 km)	2,1 kg
700021	FTB-200 + FTB7400	1310 / 1550 / 1625 nm	42/41/41 dB (max. 400 km)	2,1 kg
700021	FTB-200 + FTB7500	1310 / 1550 nm	45/45 dB (max. 400 km)	2,1 kg

The OTDR unit does not come with a fibre optical microscope, adapters, front or back measuring fibres

## ETHERNET TEST EQUIPMENT



Product category	Name	Information
600180	FTB-200 + FTB8510B moduuli	8510B: +Ericsson LG compatible 1000BASE-LX SFP Transceiver, 1310nm, 10KM, Single-mode, LC Duplex, 1.25G
600182	FTB200+ FTB8510G+ FTB8310B	8510B: +Ericsson LG compatible 1000BASE-LX SFP Transceiver, 1310nm, 10KM, Single-mode, LC Duplex, 1.25G. 8510G: +Transceiver 10GBASE-LR, 1310nm, 10500Mbps(Tx), 10500Mbps(Rx), 10km, LC Connector, Panel Mount +10GBASE-ER, Duplex LC connector, and OC-192/STM-64/10G SONET ER LC, 40 Km, 1550 nm XFP transceiver + 10 Gigabit Ethernet, and 10G Fibre Channel. PicoLight PL-XXL-SC-S45-22 transceiver has a maximum reach of 400m at 10.3125 Gb/s data rate. This product features an 850nm VCSEL Laser, duplex LC connector.
600182	FTB1+ FTB880	EXFO-TK-FTB-880-FLEX-10GIGE/F1 Modular Test Kit 10GigE SONET SDH PDH/1G-Elec & Optical 1GigE/FCALL-Fiber Channel 1,2,4,8,10/ STMI-155Mbit/s Optical Rate/STM16-2488Mbit/s Optical Rate/STM4-622Mbit/s Optical Rate/STM64-10Gbit/s Optical Rate

## FIBRE INSPECTION PROBES



Product category	Name	Image transm	Mount	Pass/fail function	Further information
700080	EXFO FIP-400	Analog	8-pin mini-DIN	no	Equipped with a separate display. Fibre inspection probe only.
700082	FBP-HD1/FIP-S	Analog	8-pin mini-DIN	no	Fibre inspection probe only. Equipped with a built-in display.
700086	EXFO FIP-410B	Digital	USB	no	Equipped with a separate display.

### OPTICAL POWER METER



Product category	Name		Wave-lengths	Precision	Further information	Connections
700042	Optical power FHP2A04 + Transmitter FHSD02	Battery	1310 nm/ 1550 nm	Receiver: 0.01 dB @ -60 to +10 dBm Optical laser: 15 min: <0,1 dB (=5h): <0,2 dB	USB nterface Data storage Resolution: -§5,0 dBm	FC/PC Fibre connector FC/PC onnector

### OPTICAL LOSS METERS



Product category	Name		Wavelength	Further infor- mation	
700040	FOT-930 Maxtester	Battery	1310 nm / 1550 nm	Power meter, transmitter and VFL in one device. Also measures optical fibre length and ORL.	FC/PC connector Receiver resolution: ± 5 % @ 10 to -70dBm Laser source ower/resolution: -1,0dBm ± 0.05dB (8h)

### SPLICING TRAILERS Product category 800060



- Size 16 x 1.7 m
- Unbraked trailer with a 50mm ball hitch mount and trailer lights (12V)
- Locking fibre-reinforced plastic toolbox on the drawbar
- Window double-glazed thermal glass.
- Insulated cable door with a brush-equipped cable hatch
- Lighting, power outlets and an exhaust fan, power supply 230V (caravan plug)

## COPPER NETWORK INSTRUMENTS

### Cable analyzer for copper cable certification



Product category	Name	Measurements	Further information	Included
600060	Fluke DSX-5000	TIA/CAT: 3; 4; 5; 6; 6A	Autotest speed: CAT5e, or 6 Class D or E: 9 seconds  CAT6A Class EA: 10 seconds	<ul style="list-style-type: none"> <li>• CAT 6A/Class EA Permanent Link adapter set</li> <li>• CAT 6A/Class EA Channel adapter set</li> <li>• USB cable</li> <li>• 2 laturia</li> </ul>
600062	Fluke DSX-600Pro	TIA/CAT: 3; 5; 6; 6A	Autotest speed: CAT6A Class EA: 10 seconds	<ul style="list-style-type: none"> <li>• 2 x CAT 6A/Class EA Permanent Link adapter set</li> <li>• 2 x CAT 6A/Class EA Channel adapter set</li> <li>• USB cable</li> <li>• Charger</li> </ul>
600062	Fluke DTX-1800	TIA/CAT: 3; 5; 5e; 6; 6A	Autotest speed: CAT6A class Ea:10 seconds	<ul style="list-style-type: none"> <li>• 2 x Cat 6/Class E Permanent Link adapter</li> <li>• 2 x Cat 6/Class E Channel adapter</li> <li>• 2 charges</li> <li>• USB caple (Mini-B)</li> </ul>
600063*	Fluke DTX-1800-SFM fibre adapters*	Single fibers 1310 nm/1550 nm		<ul style="list-style-type: none"> <li>• Connections:</li> <li>• SC/SC nd ST/ST adapters</li> </ul>

\*requires a separate DTX-1800 analyser



## XDSL TESTERS



Product	Product no	Manufacturer	ADSL/2+	VSDL2	SHDSL (2/4)	SHDSL (2/4/6/8)	ISDN/POTS	IP-TV	VoD-test	VoIP	E 1/2 MBITS
ARGUS 145	600003	Intec	x		x		x	x	x	x	
KURTH KE 3600	600001	Intec	x	x		x	x	x	x	x	
ARGUS 145+	600001	Intec	x	x		x	x	x	x	x	
SMARTCLASS TPS	600009	Viavi	x	x							
ARGUS 42	600015	Intec	x				x			x	
ARGUS 41+	600015	Intec	x								
ARGUS 141	600009	Intec	x	x				x		x	
ARGUS 142	600009	Intec	x	x			x	x	x	x	
TLP-3C	600100	Grandway									x
SMARTCLASSEI	600102	JDSU									x

## TDR-NSTRUMENTS



Model	Product category	Current	Display	Impedance $\Omega$	Operating range	Measurement ranges	Weight	Included
TDR-44	600040	Battery 6xAA	LCD 128x64 backlit		3 km	0,1/0,3/1/3	0,5 kg	
PJT-6	600144	Battery 9V	LCD	90-150	1 km	1 m - 1,5 km	0,4 kg	Case, measuring wires, user instructions
PJT-10	600142	Battery 30 h	LCD backlit Zoom: 1x, 2x, 4x	60-150	12 km	0,38/0,76/1,5/ 3/6/12	2,5 kg	Carry case, charger, instruction manual, 2 fused test lead pairs
PJT-11	600140	Battery LR14 pcs/40h	LCD backlit	100	4,8 km	0,35/0,85/1,9/4,8	1,2 kg	Carry case, instruction manual, quick guide, fused test lead pair
TDR 2000/2R	600146	8 x AA batteries	320x240 LCD backlit	120	50 m-16 km	50m/0,1/0,2/0,4/ 1/2/4/8/16	1,5 kg	Carry case, instruction manual, charger
TDR 2000/3	600146	Battery	800x480 LCD	125	max. 20 km	Optional choices	2 kg	2 m test leads, charger, instruction manual

## FIELD STRENGTH METERS, RF METERS, OTHER NETWORK TOOLS



Manufacturer	PROMAX	JDSU	SITEMASTER
Product category	600124	600122	600022
Model	HDRanger Lite	DSAM6300	S331D
Frequency	5-1000 MHz	4-1000 MHz	25-4000 MHz
Intended use	Field strength meter for analog and, in particular, digital satellite and antenna installations.	Testing digital and analog field strength service.	Antenna tester, cable and antenna testing, radio network tester, RF tester General base station repeater installations.
Features	<ul style="list-style-type: none"> <li>• DVB-T/C/S/S2, QAM Annex C, DSS</li> <li>• Spektrum analysis</li> <li>• MPEG-1, MPEG-2, MPEG-4 AVC H. 264</li> <li>• StealthID</li> <li>• H. 265 detection</li> </ul>	<ul style="list-style-type: none"> <li>• Bidirectional Sweep</li> <li>• DOCSIS 3.0</li> <li>• Spektrum analysis</li> <li>• QAM analyser</li> <li>• Signal strength meter</li> <li>• Stealth sweep</li> <li>• MER / Annex A, B, C</li> </ul>	<ul style="list-style-type: none"> <li>• Return loss = Line sweep</li> <li>• VSWR</li> <li>• Cable loss sweep</li> <li>• Distance-To-Fault</li> <li>• Spektrum analysis</li> </ul>
Weight	1,6 kg	2 kg	4 kg



## ELECTRICIAN INSTRUMENTS



Name		
Fluke 1653 B	Installation tester	<ul style="list-style-type: none"> <li>• AC voltage measurement: 500V</li> <li>• Continuity testing: 20 / 200 / 2000Ohm</li> <li>• Insulation resistance: 250/500/1000V</li> <li>• Loop impedance: 100-500VAC</li> <li>• PEFC/PSC (fault/short-circuit current) A, AC, F, G/R, S</li> </ul>
Fluke 1525-2	Earth ground tester	<ul style="list-style-type: none"> <li>• 3- and 4-pole fall-of-potential, earth resistance loop testing</li> <li>• 4-pole soil resistivity testing</li> <li>• Selective earth ground rod testing using 1 clamp</li> <li>• Selective earth ground rod testing using 2 clamps</li> <li>• IP56 rated for outdoor use</li> </ul>
Megger MIT515	Insulation resistance tester	<ul style="list-style-type: none"> <li>• Automatic insulation resistance (IR),</li> <li>• Timed IR(s)</li> <li>• Polarisation Index (PI),</li> <li>• Dielectric Absorption Ratio (DAR)</li> <li>• Safety rating: CAT IV 600V</li> <li>• Test voltage: 100-5000V (25V steps)</li> <li>• Resistance range: 10k Ohm- 10 TOhm</li> <li>• Accuracy: +/-5% (1000 Ohms) / +/-20% (over 1000 Ohms)</li> </ul>



# OTHER TOOLS

## WORKBENCHES

Product category	Name	Size (L x W x H)	Weight	Further information
310400	Ridgid Matador	1000 x 625 x 840 mm	28 kg (bench weight)	Equipped with a bench vise and pipe clamp
310404	Ridgid 1100	830 x 80 x 800 mm	21 kg	Lightweight work table
310402	2740771	2000 x 800 x 800-1200	60 kg	Adjustable height, two levels, casters



## DRY-CUT SAWS/METAL SAWS



Cuts steel, copper, aluminium and plastic cleanly with nearly no shavings. Adjustable cutting angle 45° - 90°.

Product category	Name	Power	Weight
860201	Ridgis 590 L, 230V	2200W, 1300rpm	23 kg
Blades	Name	Designer for	
100956301058	Swblade Ridgid 590L - 58476, 80 H (350 x 2,2 x 25,4 mm)	Fe, Cu, Al and lastic. Max. material thickness: 6mm	

Application table

Profile	Maximum dimensions (mm)		Max. wall thickness at max. dimensions				
	<32 RC 90°	<32 RC 45°	Ferrous metal	Copper/Zink	Brass	Aluminium	PVC AB5
○	130 mm	100 mm	>0,5<6 mm	>0,5<6 mm	>1,5<4 mm	>0,5<6 mm	>0,5<6 mm
□	115 x 115 mm	90 x 90 mm	>0,5<6 mm	>0,5<6 mm	>1,5<4 mm	>0,5<6 mm	>0,5<6 mm
▭	95 x 180 mm	90 x 100 mm	>0,5<6 mm	>0,5<6 mm	>1,5<4 mm	>0,5<6 mm	>0,5<6 mm
└	85 x 85 mm	75 x 75 mm	>0,5<6 mm	>0,5<6 mm	>1,5<4 mm	>1,0<6 mm	>0,5<6 mm

The material thickness specified is a recommendation of the given profile hardness at the maximum dimensions.



## BAND SAWS FOR METAL



Product category	13222	13222
<b>Nme</b>	Opti S275G	Opti S350G
<b>Motor</b>	1,1 kW / 400V	2,2 kW / 400V
<b>Weight</b>	200 kg	440 kg
<b>Capacity 0°</b> <b>Round</b> <b>Rectangular</b> <b>Square</b>	Ø225mm 245 x 180mm 180 mm	Ø 270mm 350 x 240mm 260mm
<b>Capacity +45°</b> <b>Round</b> <b>Rectangular</b> <b>Square</b>	Does not turn in both directions	Ø230mm 230 x 150mm 210mm
<b>Capacity -45°</b> <b>Round</b> <b>Rectangular</b> <b>Square</b>	Ø 160mm 160 x 160 mm 160 mm	Ø200mm 200 x 140mm 140mm
<b>Capacity -60°</b> <b>Round</b> <b>Rectangular</b> <b>Square</b>	Ø100mm 100 x 100mm 100 mm	Ø140mm 140 x 140mm 140mm
<b>Use</b>	Manual blade lift Hydraulic feed	Manual blade lift Hydraulic feed
<b>Further information</b>	Sawing fluid available	Sawing fluid available
<b>Blade (sold eparately)</b>	100956301045 2480 x 27 x 0,90 mm	100956301029 2925 x 27 x 0,9 mm
<b>Accessories</b>	13029 Feeder table set 1 / 2m	13029 Feeder table set 1 / 2m

## ANGLE GRINDERS

	Product category§	Name*	Flange		Max. pm	Vibration m/s <sup>2</sup>	Weight	Further information
	318	Makita BGA452RFE	115 mm	Battery (3,0Ah)	10 000 rpm	8,5	1,9 kg	Comes with two batteries
	318	Makita DGA504RTJ	125 mm	Battery (5,0Ah)	8 500 rpm	6,0	2,5 kg	Comes with two batteries
	319	Makita GA5040CF01	125 mm	230 V	2800-11 000 rpm / 1400 W	5,5	2,5 kg	Stepless speed control
	319	Metabo WEPBA 14-125 QUICK PROTECT	125 mm	230 V	7000- 10500 rpm / 1400 W	6,5	2,6 kg	Stepless speed control Dead-man switch
	320	Makita GA6040CF01	150 mm	230 V	4000-9000 rpm / 1400 W	6,0	2,6 kg	Stepless speed control
	320	Makita 9566CF	150 mm	230 V	9000 rpm / 1400 W	7,0	2,6 kg	Without adjustment
	3200	Metabo WEA17-150 QUICK	150 mm	230 V	9600 rpm / 1700 W	4,5	2,5 kg	Without adjustment 1700W
	3202	Makita GA9040SF01	230 mm	230 V	6600 rpm / 2600 W	5,5	6,7 kg	Without adjustment
	3202	Metabo W 22-230	230 mm	230 V	6600 rpm / 2200 W	4,8	5,8 kg	Without adjustment
	324	Atlas Copco GTG40 F066-23 (turbo)	230 mm	Compressed air	6600 rpm	-	4,0 kg	Compressed air without adjustment

\*Example products

## DIE GRINDERS



Product category	Name*	Chuck		Max. rpm	Vibrations m/s <sup>2</sup>	Weight
656004	Makita GD0800C	6 mm	230 V	7000-28000 rpm	2,5	1,7 kg
656004	Metabo GE710PLUS	6 mm	230 V	10 000-30500 rpm	5,6-16,9	1,6 kg
654203	Atlas Copco LSF 27 S250	6 mm	Pain-eilma	25000 rpm	-	1,0 kg

\*Example products

## RIVET NUT TOOLS



Product category	Name		Rivet nuts	Power	Stroke	Weight	Includes tools
660008	Gesipa FireBird	Battery 14,4 V	Al: M4-M10 Fe: M4-M8 RST: M4-M6	13000 N	5,5 mm	2,1 kg	M4, M5, M6, M8, M10

## BLIND RIVET TOOLS



Product category	Name		Blind rivet tools	Power	Stroke	Weight	Nose pieces included
660013	Gesipa AccuBird	Battery 14,4 V	Ø 3-5mm (Al, Fe, RST)	10000 N	20 mm	2,0 kg	17/24, 17/27, 17/29, 17/32

## THREADED ROD CUTTERS



Product category	Name		For rods	Weight	Further information
660014	Makita SC120DRA	Battery 12 V	M8, M10, M12	4,0 kg	Blades: 100956302014 M8 100956302015 M10 100956302019 M12
660014	Hitachi CL18DSL 2LLRK	Battery 18 V	M8	3,2 kg	Blade: 100956302011 M8
660006	Ridgid 1390M – M8	Manual	M8	5,4 kg	Blade: 100956302004
660006	Ridgid 1390M - M10	Manual	M10	5,4 kg	Blade: 100956302003

## BEVELLER

### TRUMPF TKF 1500-0



Max. chamfer lengths 15 mm

- material thickness 400 N/mm<sup>2</sup> ls max. 15 mm
- material thickness 600 N/mm<sup>2</sup> ls max. 11 mm
- material thickness 800 N/mm<sup>2</sup> ls max. 7.5 mm

<b>Chamfer angle</b>	stepless adjustment 20°-45°
<b>Smallest radius</b>	55 mm
<b>Working speed</b>	n. 2 m/min
<b>Nominal power</b>	2000 W
<b>Stroke rate</b>	at full load 370/min
<b>Weight</b>	16,5 kg

## UNCH DRIVERS



Product category	Name		Power	Weight	Further information	Included
320002	Greenlee 7804F	Manual	8 ton	3,4 kg	Fe: 3,0 mm RST: 1,5 mm Light metal: 4,0 mm Plastic: 4,0 mm	60 mm 47 mm 37 mm 15,2 mm 18,6 mm 20,4 mm 22,5 mm 28,3 mm 32,5 mm
320002	RUKO 109009	Manual	5 ton	5 kg	Fe: 3,0 mm RST: 1,5 mm Light metal: 4,0 mm Plastic: 4,0 mm	M16 16,5 mm M20 20,4 mm M25 25,4 mm M32 32,5 mm M40 40,5 mm M50 50,5 mm
320003	Enerpac MSP-351	Separate 700 bar pump	35 ton	21 kg	12,7 mm standard steel	9,5 mm 11,1 mm 13,5 mm 17,5 mm



### HYDRAULIC PULLER

PH1002-220

- 100 t, 2-aw, hydraulic puller on a wheeled frame
- Stroke: 260 mm
- Spread: 1219 mm
- 1067-864 mm
- Weight 400 kg

### PMR TELEPHONES



Product category	Name		Power	Weight	Further information
805101	Kenwood TK-3301	Battery (duration approx. 20 h)	n. 3 km	280 g	16 hannels (Kenwood channel spacing 12,5 kHz)
805101	Kenwood TK-3501 Pro	Battery (duration approx. 20 h)	n. 9 km	210 g	16 hannels (Kenwood channel spacing 12,5 kHz)



### FIRE EXTINGUISHERS

POWER EXTINGUISHER 6 kg, 12 kg

Prduct category 446



### HOT WORK CARTS

Product category	Name		Included	Weight
444	Hot work truck Battery	Space for two 12 kg extinguishers <b>Extinguisher not included</b>	Fire blanket + glove	13 kg

## LADDERS AND WORK PLATFORMS



Product category	Name	Platform height	Steps	Weight
1520	KRP-50/70	50 cm	2 (2 sided)	8 kg
1521	KRP-70/70	70 cm	3 (2 sided)	9,5 kg
1521	KRP-90/70	90 cm	4 (2 sided)	11 kg
1509	TT-104	94 cm	4 kpl	8 kg
1509	TT-106 P	146 cm	6 kpl	10,5 kg
1510	4T-108 P	198 cm	8 kpl	14 kg

\*Meets the requirements specified in Government decree VNA 205/2009 and the Confederation of Finnish Construction Industries RT 'General instructions applying to work stands

## IXOLIFT MOBILE ELEVATING WORK PLATFORMS



- Compact, gas spring-powered work platform
- **Also available in ATEX2-compliant models**
- Height adjustable in 5 cm increments
- Front wheels automatically lock
- Machinery Directive 2006/42/EC and EN 280/2013 & EN 1004/2004 standards

Product category	Name	Use	Platform height/capacity	Load	Weight	
1522	400S	Indoors	974-3974 mm (530 x 550 mm)	max. 150 kg	140 kg	Can be lowered and transported on its side
	400 WS	Indoors / outdoors			239 kg	Extra ballast weights allow for indoor use of the platform without needing the stabilisers

### LONG REACH SCALERS



Product category	Name	Length	Blows/min	Weight	Further information	Attachments
9005	Trelawny LR5	1400 mm	2200	3,4 kg	Air consumption: 126 L/min Noise: 84.2 dB (A) Vibration level: 10.3 m/s <sup>2</sup> Connection: 3/8" bsp	Toolheads vary by CC.

### PENCIL DRILL DRIVERS



Product category	Name		RPM	Torque	Weight	Further information
10409	Makita DF010DSE	Battery 7,2 V	200/650 rpm	5,6 Nm	0,5 kg	21 torque settings Job light
10409	Panasonic EY6220	Battery 2,4 V	200/400 rpm	2 Nm	0,4 kg	Torque adjustment

### METAL CORE DRILLING UNITS 220-240 V

Bits sold separately.



Product category	Name		Included	Feed/magnetic force	Weight	Maximum bits
10415	Fein KBM 32Q	440 rpm	<ul style="list-style-type: none"> <li>• Chuck: 1,5-13 mm + key</li> <li>• Removal wedges</li> </ul>	130 mm/9000 Nm	10,5 kg	Carbide core drill bit 32mm Twist drill bit 13mm Thread tap M12
10415	Fein KBM 52U	130-260rpm/ 260-520 rpm	<ul style="list-style-type: none"> <li>• Chuck: 1,5-13 mm + key</li> <li>• Removal wedges</li> </ul>	135 mm/11000 Nm	13,7 kg	Carbide core drill bit 50mm Twist drill bit 23mm Thread tap M16
10415	Ruko RSM40E	60-140 rpm/200-470 rpm	<ul style="list-style-type: none"> <li>• Chuck: 3-13 mm + key</li> <li>• Removal wedges</li> <li>• MK3-chuck</li> </ul>	190 mm/11000 Nm	21 kg	Carbide core drill bit: 100mm DIN338 16mm DIN345 32mm Thread tap M30



# OTHER METERS AND INSTRUMENTS

## THERMOMETERS



Product category	Name	Measurement range		Weight
841302	Fluke 62 Max	-30 - 500°C ± 1,5% (-10...-30°C 3%)	Measurement with IR laser. Measurement range between lasers: 0.3 kg min/max/avg/diff erence	0,3 kg
841302	Center 307	-200 - 1370° C ± 0,3 %	Measurement with sensors. Displays the object temperature	0,2 kg

## SOUND LEVEL/LIGHT METER



Product category	Name	Range / accuracy	Further information	Weight
17015	TM-103 Sound level meter + TM-203 Light meter Comes in a case	30-130 dB ± 1,5 dB	IEC 61672, II Datalogger	1,0 kg
		20-200 000 Lux ± 6 %	JISC1609: 1993; CNS5119 Datalogger	

## DYNAMOMETERS

Device for measuring large forces. The device extends approx. 10 mm at maximum.



Product category	Manu- facturer	Model	Capacity	Units (accuracy)	Length (on-center spacing)	Weight
841314	PIAB	B	1000 kg	20 kg / 2 mm	230 mm	1,9 kg
841314	PIAB	M	2000 kg	25 kg / 2,3 mm	327 mm	7,8 kg
841314	PIAB	O	3000 kg	50 kg / 2,5 mm	327 mm	7,8 kg
841314	PIAB	Q	5000 kg	50 kg / 2,5 mm	329 mm	15 kg

## ROPE TENSION METERS



A rope tension meter measures the tension of guy wires. When erecting masts, the mast is stabilised by guy wires (2-4 per mast). Calibration certificates included.



Calibrated:

7,3 mm

9,2 mm

10,6 mm

13,1 mm

15,4 mm

Other thicknesses available with a roughly 2-week delivery time

Manufacturer	Model	Capacity	Cable thickness	Measurement/precision	Weight	
PIAB	RT-M20D	5 t	6-38 mm	Digital 2-6%	6,2 kg	Battery life: approx. 25 hours

## PERSONAL RADIATION MONITORS



Antennas, radars and devices that emit powerful electromagnetic fields for heating, melting or joining materials are usually sources of hazardous radiation. RadMan XT offers protection when working in these types of environments by warning the user of hazardous electromagnetic fields.

Four LEDs indicate the electromagnetic radiation flux density in stages of 12.5%, 25%, 50% and 100%.

RadMan monitors have both electric (E) and magnetic (H) field sensors for reliable warning regardless of the distance from the source.



Product category	Name	Frequency range	Operating temperature	Weight
841307	RADMAN 2250/56	100 MHz	-10° C - 55°C	0,13 kg



RoCam 4



RoScope i2000

## PIPE INSPECTION CAMERAS/INSPECTION CAMERAS

Cameras equipped with LED lights, data storage option, self-levelling imager head and display for use in tight spaces and pipes.

Product category	Name	For pipes $\varnothing$	Cable length	Camera $\varnothing$	Weight
331002	RoCam 4	70-150 mm	65 m	30 mm	18 kg
331002	RoScope i2000/ Module TEC	50 - 100 mm	16 m/1 m	25 mm / 17 mm	5 kg



# TOOLKITS



## INSTALLER TOOLKIT

The following tools are included in the toolkit (**unless otherwise agreed**)

**NOTE! Not included in the toolkit price**

- Lever chain hoist Kito NLX005, 500 kg / Lifting height 6 m
- Angle grinder Metabo We 14-150 Plus, 6"
- Angle grinder Metabo W 23-230 Plus, 9"
- Die grinder Metabo GE 700 (7,000-27,000 r/min) [5.5 h]

QTY, PCS	RODUCT NAME
1	Socket, # 1/2", 10-32 mm
1	Folding hex key set 2,5-10 mm
1	Folding Torx key set T9 - T40
1	Combination wrench 10 mm (1952 M)
1	Combination wrench 13 mm (1952M)
1	Combination wrench 17 mm (1952M)
1	Combination wrench 19 mm (1952M)
2	Combination wrench 24 mm (1952M)
1	Combination wrench 27 mm (1952M)
1	Combination wrench 30 mm (1952M)
1	Combination wrench 36 mm (1952M)
1	Combination wrench 41 mm (1952M)
1	Striking face box end wrench 30 mm
1	Striking face box end wrench 36 mm
1	Striking face box end wrench 41 mm
1	Pipe wrench 143/555 mm (78/3,10 in.)
1	Pipe wrench 320/1 1/2", 442 Bahco (kitaväli 40 mm)
1	Pipe clamp gripping pliers GRZRO 0-110 mm
1	Combination pliers 180 mm, insulated
1	Slip joint pliers Knipex 250 mm, 87 01 250 (6-46 mm)
1	Adjustable wrench 31 / 8" Alligaa
1	Adjustable wrench 12"
1	Warrington hammer 340 g.
1	Forge hammer 1500 g.
1	Screw clamp 120x300
1	Chalk holder
1	Divider w/ 250 mm spring
1	Hand chisel 150-200 mm
1	Flange square 500/250 mm
1	Plywood case K380, S420, L810

QTY, CS	PRODUCT NAME
1	Right angle 250 mm
1	Right angle 50/600 mm
1	Pry bar 45 cm (fitting)
1	Jaakari DP, with replaceable heads
1	Hacksaw
1	Keyhole saw "Stiletto 210" (Compass saw)
1	Tape measure 5 m/25 mm
1	Measuring tape 20 m "bell"
1	Scribe, soldered hardened metal
1	Punch 265/150
1	File (half-round) 10" semi-hardened
1	Plumb bob 400 G
1	Level 23 cm "MAGN." alum. + angle device 60 cm
1	Screwdriver 0,8x4,0x100 mm
1	Screwdriver 1,0x6,5x100 mm
1	Screwdriver 1,2x8,0x125 mm
1	Screwdriver PH-2x100 mm
1	Mora utility knife 546 (tainless steel)
1	Cup-type spark lighter
1	Torch "Flat"
1	Safety glasses (clear)
1	Gas welding goggles
1	Round sling 1000 kg 1/2 m
1	Extension cable 10 A 2-/3-os.
1	Voltage detector 150-240 V
1	Scribing strip 0,20 x 50 mm / RST, 1,67 m
1	Scribing strip 0,20 x 100 mm / RST, 1,67 m
1	Toolbox / helf
1	Abloy lock 3020 C



## MECHANIC TOOLKIT

The following tools are included in the toolkit (**unless otherwise agreed**)

**NOTE! Not included in the toolkit price**

- Lever chain hoist Kito LB008, 0.75 t / Lifting height 6.0 m
- Hand-held drill 230V, 13 mm chuck

QTY, CS	PRODUCT NAME
1	Socket set, # 1/2", 10-32 mm
1	Adjustable wrench 6"
1	Adjustable wrench 8"
1	Adjustable wrench 12"
1	Adjustable wrench 18"
1	Combination wrench 8 mm (1952M)
1	Combination wrench 9 mm (1952M)
2	Combination wrench 10 mm (1952M)
1	Combination wrench 11 mm (1952M)
1	Combination wrench 12 mm (1952M)
1	Combination wrench 13 mm (1952M)
1	Combination wrench 14 mm (1952M)
1	Combination wrench 17 mm (1952M)
1	Combination wrench 19 mm (1952M)
1	Combination wrench 22 mm (1952M)
1	Combination wrench 24 mm (1952M)
1	Combination wrench 27 mm (1952M)
1	Combination wrench 30 mm (1952M)
1	Combination wrench 32 mm (1952M)
1	Combination wrench 36 mm (1952M)
1	Combination wrench 1/4" mm (1952Z)
1	Combination wrench 11/32" mm (1952Z)
1	Combination wrench 1/2" mm (1952Z)
1	Combination wrench 5/8" mm (1952Z)
1	Kiintolenkki 3/4" mm (1952Z)
1	Combination wrench 7/8" mm (1952Z)
1	Combination wrench 1" mm (1952Z)
1	Combination wrench 1 1/16" mm (1952Z)
1	Combination wrench 1 1/8" mm (1952Z)
1	Combination wrench 1 1/4" mm (1952Z)
1	Box gasket remover set
1	Flat file 10" (8019426)
1	File (half-round) 10" semi-hardened
1	File (round) 10" (8020347)

QTY, PCS	PRODUCT NAME
1	Pipe wrench 143/555 mm (78 mm/3,10 in)
1	Folding hex key set 2,5-10 mm
1	Screwdriver 0,8x4,0x100 mm
1	Screwdriver 1,0x6,5x100 mm
1	Screwdriver 1,5x10x150 mm
1	Circlip pliers straight (for external circlips)
1	Circlip pliers straight (for internal circlips)
1	Combination pliers 180 mm, insulated
1	Locking pliers
1	Diagonal insulation stripper Knipex 140 mm, 74 02 140 for hard wire
1	Slip joint pliers Knipex 250 mm, 87 01 250 (6-46 mm)
1	Combination shears
1	Mandrel set
1	Divider w/ 250 mm spring
1	Hand chisel 150-200 mm
1	Bearing scraper
1	Flat scraper 25 mm
1	Plastic face hammer 340 g
1	Warrington hammer 340 g
1	Forge hammer 1500 g
1	Metal snips (straight)
1	Scribe (soldered hardened metal)
1	Punch 265/150
1	Mora utility knife 546 (stainless steel)
1	Hacksaw
1	Ruler approx. 300 mm
1	Tape measure 3 m
1	Calipers 150 mm
1	Feeler gauge 13 blades (B12 6)
1	Torch/flaslight "Flat"
1	Steel brush
1	Abloy lock 3020C
1	Plywood case K380, S420, L810



## HVAC INSTALLER TOOLKIT

The following tools are included in the toolkit (**unless otherwise agreed**)

**NOTE! Not included in the toolkit price**

- Angle grinder Metabo We 14-150 Plus, 6"

QTY, PCS	PRODUCT NAME
1	CU cutter 104 (-24 mm)
1	CU cutter 150-L (3-35 mm)
1	Spreader pliers 10-35 mm
1	CU bending pliers 310-M, 10 mm
1	CU bending pliers 312-M, 12 mm
1	CU bending pliers 315-M, 15 mm
2	Goliath ork light 38W
1	Warrington hammer 340 g
1	Socket 10 mm 1/2", Hexagonal
1	Socket 13 mm 1/2", Hexagonal
1	Socket 17 mm 1/2", Hexagonal
1	Socket 19 mm 1/2", Hexagonal
1	Socket 24 mm 1/2", Hexagonal
2	Adjustable wrench, V-jaw 31/8" Alligaa
2	Extension cable 10 A 2-/3-ps.
1	Extension shaft 1/2" rench 125 mm
1	Gas welding goggles
1	Kevlar mitt
1	Thread tap R1/2"
1	Combination wrench 10 mm (1952 M)
1	Combination wrench 13 mm (1952 M)
1	Combination wrench 17 mm (1952 M)
1	Combination wrench 19 mm (1952 M)
1	Combination wrench 24 mm (1952 M)
1	Screwdriver bit set 10-piece
1	Folding hex key set 2,5-10 mm

QTY, PCS	PRODUCT NAME
1	Folding hex key set 3/16" - 3/8"
1	Flange square 350/150 mm
1	Mora utility knife 546 (stainless steel)
1	Scribing strip 0,20 x 100 mm / SS, 1,67 m
1	Small Quick Bend former 1/2"
1	Small Quick Bend former 3/4"
1	Small Quick Bend former 3/8"
1	Small Quick Bend body and haft
2	Pipe wrench 141 (36 mm / 1,40 in)
1	Pipe wrench 142 / 370 mm (52 mm / 2,05 in)
1	Pipe wrench 143 / 555 mm (78 mm / 3,10 in)
1	Pipe wrench 320 / 1 1/2", 442 Bahco
1	Hacksaw
1	Tape measure 5 M / 25 mm
1	Screwdriver 1,0 x 6,5 x 100 mm
1	Screwdriver 1,2 x 8,0 x 125 mm
1	Screwdriver PH-2 x 100 mm
1	Screwdriver PH-3 x 150 mm
1	Ratchet wrench # 1/2"
1	Slip joint pliers Knipex 250 mm, 87 01 250 (6-46 mm)
1	Safety glasses (clear) Orion
1	Torch "Flat"
1	Level 23 cm "MAGN" alum.
1	Level + angle device 60 cm
1	Toolbox / helf
1	Abloy lock 3020 C
1	Plywood case K380, S420, L810



## WELDER TOOLKIT

The following tools are included in the toolkit **(unless otherwise agreed)**

**NOTE! Not included in the toolkit price**

- Angle grinder Metabo We 9-125, 5"
- Hand-held drill Metabo SBE 560, 13 mm chuck

QTY, PCS	PRODUCT NAME
1	Warrington hammer 340 g.
1	Forge hammer 1500 g.
1	Locking pliers for pipe 10-90 mm
1	Pipe centering clamp (mechanical) 2-5" (50-140 mm)
1	Jaakari DP, with replaceable heads
1	Keyhole saw "Stiletto 210" (Compass saw)
1	Hacksaw
1	Chipping hammer SH-3
1	Adjustable wrench, V-jaw 31 / 8" Alligator
1	Slip joint pliers Knipex 250 mm, 87 01 250 (6-46 mm)
1	Screwdriver, 1,0 x 6,5 x 100 mm
1	Screwdriver, 1,2 x 8,0 x 125 mm
1	Combination pliers 180 mm, insulated
1	Folding hex key set 2,5-10 mm
1	Hand chisel 150-200 mm
1	Scribe, soldered hardened metal
1	Punch 265/150
1	Welding mirror with mang. shaft
1	Tape measure 5 M / 25 mm

QTY, PCS	PRODUCT NAME
1	Mora utility knife 546 (stainless steel)
1	LED pen light
2	Extension cable 10 A. 2-/ 3-os.
1	Steel brush
1	Steel brush (stainless steel)
1	File (half-round) 10" semi-hardened
1	Rotameter "ARGON"
1	Cleaning disc shaft
1	Welding mask (standard)
2	Mask glass DIN 10
1	Mask glass (polycarbonate)
3	Mask glass (clear)
1	Safety glasses (clear)
1	Toolbox /shelf
1	Abloy lock 3020C
1	Plywood case K380, S420, L810



**Ramirent Finland Oy**

P.O. Box 31, Tapulikaupungintie 37, 00751 Helsinki

Customer service +358 800 171 414

[www.ramirent.fi](http://www.ramirent.fi)

**More than  
machines<sup>®</sup>**